

Horizon Seafari Quest Model 200 - 600

Owner's Manual

Release Date: February ,2014

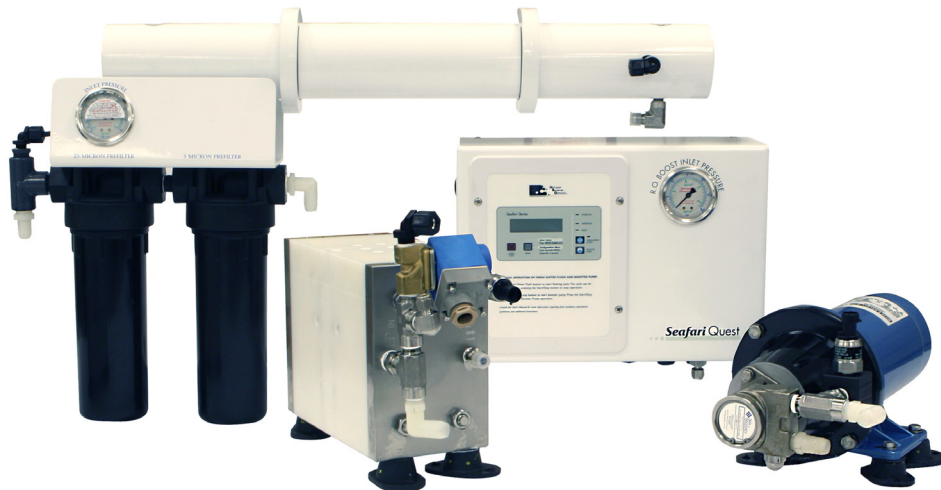

Seafari QUEST 200-600

Owner's Manual

Horizon Reverse Osmosis
Manual PN B651100001

Contents

Chapter 1: About this Manual.....	7
About Horizon Reverse Osmosis.....	7
Purpose.....	7
References.....	7
Graphics.....	7
Notice of Liability.....	8
Trademarks.....	8
Terms and Conditions.....	8
Copyright.....	8
Revision History.....	8
Chapter 2: Introduction.....	9
Welcome.....	9
Models.....	9
Parts Warning.....	9
Warranty and Registration.....	10
Safety.....	10
Disposal.....	10
Compliance.....	10
Patent Information.....	10
Chapter 3: System Specifications.....	11
Feed Water and Recovery.....	11
System Pressure.....	11
Performance.....	11
External Installation Water Connections.....	12
Feed Water Pump Motor Electrical Specifications.....	12
Operating Amperage.....	12
Weight.....	12
Chapter 4: System and Components Description.....	15
Component Functions and Descriptions.....	15
Pre-filtration Components.....	15
Pressurization Components.....	16
Brine Discharge Components.....	16
Product Water and Post-Filtration Components.....	17
Fresh Water Flush and RO Membrane Element Cleaning.....	17
Electronic Components.....	17
Plumbing Connections.....	18
Chapter 5: Pre-Installation Safety.....	21
Storage Prior to Uncrating.....	21
Uncrating.....	21
Tools required for Installation.....	21
Chemical Precautions.....	21
System Safety Check.....	22
Installer Minimum Qualifications.....	22
Warnings.....	22
Special Considerations.....	23
Components Supplied by the Installer or Owner.....	23
Chapter 6: Installation.....	25
System and Component Mounting.....	25
Electrical Connections.....	26
Hose Lines.....	27
Required Hose and Tube Connections.....	27
Ultraviolet (UV) Light Installation.....	28
Plumbing Requirements.....	29

Install Fittings.....	29
Install Quartz Sleeve.....	29
Connect Plumbing.....	29
Install Lamp.....	30
Operational Notes.....	30
Compact Installation Drawing.....	31
Modular Installation Drawing.....	32

Chapter 7: Commissioning a New System.....33

New System Start-up Procedures	33
Pressure Changes.....	35
Horizon Reverse Osmosis Seafari Quest NEW SYSTEM INITIAL READINGS.....	36

Chapter 8: System Daily Operation.....37

Day-to-Day Start-up Procedures for the Seafari Quest System.....	37
Controller Operations.....	38
Display Menu.....	38
Configuration (Change) Menu.....	39
Configuration (Read) Menu.....	39
Fresh Water Flush button.....	40
Shutting Down the Seafari Quest System.....	40

Chapter 9: System Storage and Cleaning.....41

Membrane Element Handling and System Storage Warnings.....	41
Fresh Water Flush.....	41
System Storage.....	42
Fresh Water Flush.....	42
Automated Fresh Water Flush.....	42
Manual Fresh Water Flush.....	42
Once-Through Depressurized Rinse.....	42
RO Membrane Element Cleaning Closed Loop.....	43
Short-Term Shutdown.....	43
Long-Term Shutdown.....	45
RO Membrane Element Cleaning Procedures.....	46
Closed Loop Configuration.....	49

Chapter 10: Troubleshooting.....51

Error ID 1: High Pressure Fault.....	51
Error ID 2: High Pressure Fault.....	51
Error ID 3: Low Pressure Fault.....	51
Error ID 4: Low Voltage Fault.....	52
3-Way Product Water Diversion Valve Abnormalities	52
High-Pressure or Low-Pressure Abnormalities Due to Mismatch of Components.....	52
Product Water Abnormalities.....	53
Lower-Than-Normal Product Water Flow.....	53
Higher-Than-Normal Product Water Flow.....	54
Low Product Water Quality (Increased Salt Content in the Product Water).....	54

Chapter 11: Electrical Information.....55

Electrical Requirements.....	55
------------------------------	----

Chapter 12: Exploded Parts View.....59

H011M SEAFARI QUEST MODULAR	59
H010C SEAFARI QUEST COMPACT	61
B006380002 SEA STRAINER UWDX 5IN.....	63
ETD-PUMP ASSY (13%)- COMPACT & MODULAR.....	64
FEED PUMP UWDX-SQC 200-400 1/3HP 12VDC.....	65
B007380023 FEED PUMP UWDX-SQC 600-12V.....	67
FEED PUMP UWDX-SQC 200-400 1/3HP 24VDC.....	69
B007380024 FEED PUMP UWDX-SQC 600 1/2 24VDC.....	71
FEED PUMP SQM 200-400 1/3 12VDC- MODULAR UNIT.....	73
H007110023 FEED PUMP SQM 600-12V.....	75
FEED PUMP SQM 200-400 1/3HP 24VDC- MODULAR UNIT.....	77
H007110024 FEED PUMP SQM 600 1/2 24VDC.....	79

H515111002 LP BACK PLATE ASSY SQM.....	81
B107380004 PREFILTER ASSY UW-SE M4-600.....	82
MEMBRANE VESSEL 200 - 600 GPD UWDX-SQC COMPACT.....	84
MEMBRANE VESSEL 200 - 600 GPD MODULAR.....	86
H2521210001 CHARCOAL FILTER ASSY.....	88
B561080001 PH NEUTRALIZER ASSY 0.5-1.5 GPM.....	90
B591120001 CLEAN AND RINSE KIT.....	92
B598000005 FRESH WATER FLUSH UWDX-SQC.....	94
B516010001 DIVERSION VALVE ASSEMBLY.....	96
1401096100 3-WAY PRODUCT WATER DIVERSION SOLENOID VALVE.....	97
B5262000CV UV STERILIZER.....	98
H2606210005 REMOTE ASSY HRO SF SE 170SF.....	100
B501290001 PLUMBING ASSEMBLY UWDX-SQC.....	101
B001290002 INSTALLATION KIT UWDX.....	103
HP HOSE ASSEMBLY.....	104
AVAILABLE TUBES AND FITTINGS.....	105
TUBE COMPRESSION FITTINGS REPLACEMENT PARTS.....	108

Chapter 1

About this Manual

About Horizon Reverse Osmosis

Since 1975, Horizon Reverse Osmosis has produced water desalination systems, used in various applications, for customers around the world. Currently, Horizon Reverse Osmosis stands apart as a leader in advanced water desalination systems for leisure marine applications.

Horizon Reverse Osmosis
P.O. Box 5288
Carson, CA 90745-5288



Purpose

This manual is intended for Horizon Reverse Osmosis's system technicians, technical support and training personnel. It contains technical information and instructions for the installation, operation, maintenance and troubleshooting of the Seafari Quest RO Desalination System. Horizon Reverse Osmosis' RO desalination systems are designed and engineered to function as complete, working units, and are subject to cascading failure if installation, operation and maintenance instructions are not followed correctly. Thus, the intent of this manual is to familiarize you, or other installer(s) and/or operator(s) with each system component. With a core understanding of the function, importance and normal operation of each subsystem component, you will be equipped to diagnose minor problems, which, if detected early on, are typically correctable. Note that if a minor component problem is left uncorrected, it can affect the rest of the system and lead to more extensive issues and/or damage.

 **Important:** Horizon Reverse Osmosis encourages you to read the Seafari Quest RO Desalination System manual thoroughly before attempting installation or operation, as well as to keep the manual for future reference. By gaining a better understanding of your system, you will be equipped with the knowledge to achieve optimum performance and a longer service life.

References

All references in this manual refer to chapters within this manual, unless otherwise specified.

Graphics

Graphics used in this manual are for reference and illustration purposes only, and may not represent the actual part or arrangement of parts in a customized system.

Notice of Liability

The information contained in the manual is distributed on an “as is” basis, without warranty. While every effort has been taken in the preparation of this manual, Horizon Reverse Osmosis shall not be held liable with respect to any liability, loss or damage caused by the instructions contained in this manual. The information contained in this manual is subject to change without notice.

Trademarks

The Horizon Reverse Osmosis® logo mark is a U.S. Registered Trademark and belongs to Horizon Reverse Osmosis with all rights reserved. Horizon Reverse Osmosis® is a U.S. Registered trademark of Horizon Reverse Osmosis. Seafari Quest is a trademark of Horizon Reverse Osmosis.

Terms and Conditions

The use of this manual acknowledges acceptance of the terms and conditions provided herewith and the agreement to comply with all applicable laws and regulations pertaining to the use of this manual. In addition, the use of this manual forms an agreement that Horizon Reverse Osmosis’s trademarked name or Horizon Reverse Osmosis’s trademarked logo mark are not to be used in any form or manner except with Horizon Reverse Osmosis’s written permission. Horizon Reverse Osmosis holds all rights to its copyrights and trademarks, and to the material contained in this manual. Any use of such requires the written permission from Horizon Reverse Osmosis.

Copyright

All content included within this manual, including text, graphics, logos and images, is the property of and protected by U.S. and international copyright laws. The compilation (i.e., the preparation, collection, arrangement and assembly) of all content within this manual is the exclusive property of and protected by U.S. and international copyright laws. All software used in the design and manufacture of the Seafari Quest RO Desalination System is the property of Horizon Reverse Osmosis and protected by U.S. and international copyright laws. All computer and logic programming used in the design and manufacture of the Seafari Quest RO Desalination System is the property of and protected by U.S. and international copyright laws. The content of this manual and the software, programming, and graphics used in the design and manufacture of the Seafari Quest RO Desalination System is for the purpose of operation, maintaining and repair of the Seafari Quest RO Desalination System. Any other use, including the reproduction, modification, distribution, transmission, republication, display or performance, of the content within this manual is strictly prohibited. © Copyright 2008 - 2014.

Revision History

Rev #	Date	Affected Pages	Description
1	March 12, 2014	Exploded parts views	Exploded parts view updates
0	October 1, 2013		Initial release of 2013 models

Chapter 2

Introduction

Welcome

Congratulations on your purchase of a new Seafari Quest Reverse Osmosis (RO) Desalination System! The Seafari Quest RO Desalination System is a low power water maker, engineered for boaters with limited electrical options. The Seafari Quest features automatic operation and is easy to use with its simple Start and Stop controls. It serves as an efficient water supply, ideal for small power boats and sail boats.



Inside this manual, you will find detailed technical information and instructions for the installation, operation, maintenance and troubleshooting of your Seafari Quest RO Desalination System.

✔ **Note:** The term "System" refers to the Seafari Quest RO Desalination System and will be used throughout this manual.

Models

The System series is available in the following compact and modular models:

- Seafari Quest Compact 200
- Seafari Quest Compact 400
- Seafari Quest Compact 600

- Seafari Quest Modular 200
- Seafari Quest Modular 400
- Seafari Quest Modular 600

Please note that your System also includes a system tag that lists the product name, model number and serial number.

Parts Warning

The major documented cause of failures and problems are from the use of third-party, non-Horizon Reverse Osmosis parts; improper installation; and improper operation. Do not use parts, components from any source other than Horizon Reverse Osmosis! The use of third party, non-Horizon Reverse Osmosis parts is strongly discouraged and will result in the following consequences:

-
- The use of third-party, non-Horizon Reverse Osmosis components, spares and assemblies will damage the Horizon Reverse Osmosis System and/or specific components within the System.
 - The use of third-party, non-Horizon Reverse Osmosis components, spares and assemblies voids any and all warranty of the System and/or voids the affected component within the System.

Horizon Reverse Osmosis maintains inventory for immediate shipment and our Service Dealers throughout the world maintain stock of Horizon Reverse Osmosis parts. Always insist on Horizon Reverse Osmosis supplied parts in order to avoid failures, eliminate problems, and maintain your warranty.

Warranty and Registration

Horizon Reverse Osmosis guarantees its product, components and replacement parts, and strongly advises that customers use only Horizon Reverse Osmosis parts. The majority of Seafari Quest RO Desalination System problems derive from premature failure of unauthorized third party replacement parts.

Using unauthorized parts will void the Horizon Reverse Osmosis warranty! Use of non-Horizon Reverse Osmosis supplied parts and accessories, including but not limited to, maintenance parts, pre-filter elements, cleaning and storage chemical, spare parts, replacement parts, system components, installation components and/or system accessories, shall void all warranty expressed or implied.

Safety

Parties responsible for the installation, operation, and maintenance of the Seafari Quest RO Desalination System must read this manual thoroughly and comply with the instructions and safety requirements at all times.

Disposal

If System disposal is necessary, you must comply with all federal and state environmental regulations.

Compliance

- Horizon Reverse Osmosis's Reverse Osmosis Desalination Systems are Type Accepted by the American Bureau of Shipping, ABS.
- Horizon Reverse Osmosis's Reverse Osmosis Desalination Systems comply with FCC § 15.105
- Horizon Reverse Osmosis's Reverse Osmosis Desalination Systems have been independently tested and determined to be in compliance with European CE (Conformité Européenne).
- Please refer to the Appendix for copies of compliance certificates.

Please refer to the Appendix for copies of compliance certificates.

Patent Information

Certain aspects of the Seafari Quest RO Desalination System are protected by U.S. and International Patent Laws.

Chapter 3

System Specifications

Feed Water and Recovery

 **Important:** If any of the following components are mismatched, the System will not function properly. The operating pressure and/or amperage draw will be higher than specified, causing damage to one or more components. The operating pressure can also be lower than required, resulting in low product water production and poor product water quality.

Table 1: 12 VDC, 24 VDC

Seafari Quest Model	Product Water Production (GPD / LPD)	Pump Elect. Mtr	Feed Pump Flow (GPH / LPH)	ETD Recovery (Percentage)	RO Membrane Element Size Code	Pressure Vessel Size Code
SQ 200	200 / 757	1/3 H.P.	100 / 379	13%	A	A
SQ 400	400 / 1514	1/3 H.P.	140 / 530	13%	C	C
SQ 600	600 / 2271	1/2 H.P.	215 / 814	13%	C	C

System Pressure

Table 2: Seawater @ 35,000 PPM and 77 F / 25° C.

Model	Feed Pump Nominal Discharge Pressure into ETD				Nominal Operating Pressure Developed by ETD at RO Membrane Element			
	PSI	BAR	Kg/cm2	kPa	PSI	BAR	Kg/cm2	kPa
SQ 200	150	10	10.5	1034	650	45	45.7	4482
SQ 400	150	11	11.2	1103	650	45	45.7	4482
SQ 600	175	12	12.3	1207	660	45.5	46.40	4550

Performance

Table 3: 12 VDC, 24 VDC

Model Number	Product water per 1 hour of operation:		Product water per 24 hours of operation:	
	U.S. Gallons	Liters	U.S. Gallons	Liters
SQ 200	8.3	32	200	757
SQ 400	16.7	63	400	1514
SQ 600	25	95	600	2271

- SALT REJECTION (CHLORIDE ION): Minimum 99.2 %, Average 99.4%
- PRODUCT WATER TEMPERATURE: Ambient to feed water temperature

- **SALINITY MONITORING:** Automatic computer controlled electronic monitoring. Temperature compensated with Water Quality Indicator. The salinity monitoring components of the System give a continuous readout in micromhos per cubic centimeter, are temperature compensated and of a fail-safe design.
- **FEED WATER SALINITY RANGE:** up to 50,000 PPM TDS (NaCl), typical seawater salinity is 35,000 PPM.
- **FEED WATER TEMPERATURE RANGE:** Max. 122°F / 50°C, Min. 33°F / .5°C.
- **FEED WATER pH RANGE:** 3-11 (typical seawater pH is 8)
- **CHLORINE TOLERANCE:** 0.1 PPM.
- **REVERSE OSMOSIS (RO) MEMBRANE:** Specifically selected High Rejection / High Yield aromatic tri-polyamides, thin film composite, spiral wound, single pass RO Membrane Element.

External Installation Water Connections

Pipe sizes to be supplied by the installer for connection of the Horizon Reverse Osmosis supplied components

Seafari Quest Compact

- Feed Inlet: 5/8" MNPT Male National Pipe Thread U.S. Standard
- Brine Discharge: 1/2" MNPT Male National Pipe Thread U.S. Standard
- Product: 1/4" FNPT Female National Pipe Thread U.S. Standard

Seafari Quest Modular

- Feed Inlet: 3/8" MNPT Male National Pipe Thread U.S. Standard
- Brine Discharge: 1/2" MNPT Male National Pipe Thread U.S. Standard
- Product: 1/4" FNPT Female National Pipe Thread U.S. Standard

Feed Water Pump Motor Electrical Specifications

12 and 24 VDC	SQ 200	SQ 400	SQ 600
	12V / 24V	12V / 24V	12V / 24V
Nominal Operating Amps	16 / 8	21 / 13	39 / 20
Maximum Motor Amps	28 / 13.4	28 / 13.4	39 / 19.5
Horse Power	.3	.3	.5
Recommended Circuit Breaker	30 / 15	45 / 20	65 / 30
Minimum Size Power Wire AWG	6 / 8	6 / 8	6 / 8
Minimum Size Power Wire mm2	13 / 8	13 / 8	13 / 8

Operating Amperage

Nominal Operating Amperage will increase if any of the following conditions exist:

- The Feed Water Temperature is lower than 77° Fahrenheit / 25° Celsius.
- The Feed Water Salinity is greater than 35,000-PPM TDS (3.5% Total Dissolved Solids).
- The RO Membrane Element becomes fouled.
- The RO Membrane Element is new and on the -15% side of the specifications.

Nominal Operating Amperage will decrease if any of the following conditions exist:

- The Feed Water Temperature is higher than 77° Fahrenheit / 25° Celsius.
- The Feed Water Salinity is less than 35,000-PPM TDS (3.5% Total Dissolved Solids).
- The RO Membrane Element is new and on the +15% side of the specifications.

Weight

MODEL	WEIGHT	MODEL	WEIGHT
SQ Compact 200	115 lbs. / 52.0 kg	SQ Modular 200	110 lbs. / 49.9 kg

MODEL	WEIGHT	MODEL	WEIGHT
SQ Compact 400	120 lbs. / 54.0 kg	SQ Modular 400	115 lbs. / 52.0 kg
SQ Compact 600	125 lbs. / 57.0 kg	SQ Modular 600	120 lbs. / 54.0 kg

Chapter 4

System and Components Description

All components supplied by Horizon Reverse Osmosis, both standard and optional, are described in this chapter, along with items that the installer must provide.

ALL STANDARD COMPONENTS AND ALL OPTIONAL ACCESSORIES.

** Denotes items supplied by installer

*** Denotes optional equipment

Component Functions and Descriptions

The Seafari Quest System is broken down into six sub-sections:

1. Pre-filtration
2. Pressurization
3. Brine Discharge
4. Product Water and Optional Post Filtration
5. Fresh Water Flush and RO Membrane Element Cleaning
6. Electronic Controls

Pre-filtration Components

The Pre-filtration section of your System filters and delivers feed water. The raw feed water is filtered to remove suspended solids larger than 5 Microns (5/1,000,000 of a meter). Pre-filtration protects the High Pressure Pump from premature wear, and the RO Membrane Element from premature fouling.

1. Inlet Thru Hull Fitting with Forward Facing Scoop** is the point at which the Feed Water enters the System. The System's Installer must use a forward-facing scoop so that the System receives positive water flow as the ship is moving.

 **Caution:** A flush Inlet Thru-hull Fitting will create a vacuum as the ship is moving, thus causing loss of Feed Water flow and cavitation of the Booster and High Pressure Pump. This will result in continuous System shut down

 **Caution:** The Installer must utilize a forward-facing scoop, so that the System receives positive water flow when the ship is moving. The fitting must be installed on the ship's hull, in a position that provides a continuous, air-free supply of Feed Water.

 **Caution:** The resulting failure of the System to remain in operation is attributed to improper installation. Thus, it is the Installer's liability, and will not be covered by the Horizon Reverse Osmosis warranty.

1. Sea Cock Valve** is used (for safety reasons) to close the Feed Water line during repair, maintenance and disuse of the System.
2. Feed Water Connector is attached to the Sea Cock Valve for connection of the Feed Water Suction Hose.
3. Sea Strainer filters out large particulate matter and suspended particles that would otherwise damage the pumps and prematurely foul the cartridge Pre-filter Element. The Sea Strainer filters and removes suspended solids larger than 100 microns and contains a cleanable filter screen.

4. Booster Pump supplies a positive pressure through the Pre-filtration components and into the Energy Transfer Device (ETD). The Booster Pump flow and pressure causes the ETD to function.
5. Check Valve Tee Assembly connects the Feed Water and the FWF Feed Water to the Feed Pump.
6. Low Pressure Transducer is located on the Feed Pump. It will automatically shut the system off when sufficient pressure is not provided to the feed pump.
7. Pre-Filter Inlet Pressure Gauge 0-300 PSI is mounted on the Pre-filter Assembly and monitors the pressure from the Outlet of the feed Pump to the inlet of the Pre-filtration.
8. Pre-Filter 25 μ m removes suspended solids 25 Microns and larger to prolong the life of the final 5 Micron Prefilter element.
9. Pre-Filter 5 μ m removes suspended solids 5 Microns and larger to prolong the life of and protect the RO Boost and Reverse Osmosis Membrane from fouling.

 **Caution:** Do not use “string-wound” or “fiber” pre-filter elements. String-wound and fiber-filter elements are designed for the Photographic Film Developing Industry. When used in sea water, they will plug much more rapidly (performance has shown within 1/10th of the time) than a Sea Recovery-supplied, Pre-filter cartridge element. This will cause frequent System shut downs and element replacement.

 **Danger:** Do not use third-party pre-filtration components! Use only Horizon Reverse Osmosis pre-filtration components. Third-party pre-filtration components do not fit properly, thus causing the seams to fall apart. They also allow bypass, which results in extensive damage to the High Pressure Pump, as well as to premature fouling of the RO Membrane Element.

10. Inline Pressure Pick-Up Tee for the Prefilter Outlet Pressure Gauge.
11. Pre-Filter Outlet Pressure Gauge 0-300 PSI is mounted on the System Control Panel and monitors the outlet pressure of the Pre-Filtration section and the inlet pressure to the Energy Transfer Device (ETD) Pump Assembly. This Gauge is used along with the Pre-Filter Inlet Pressure Gauge to determine the condition of the Pre-Filtration Elements.

Pressurization Components

The Pressurization section of your System supplies the proper pressure across the Membrane Element to produce the required product water within a safe operating condition. Proper pressure and proper flow across the Membrane Element are two basic requirements of Reverse Osmosis.

1. Energy Transfer Device (ETD) “enhances” (increases) pressure from the Booster Pump by approximately a 4:1 or 5:1 ratio.
2. Pressurized water from the feed water enters the RO Boost from the ETD port "LP IN".
3. The Low Pressure Gauge 0-300 PSI is a stainless steel glycerin filled pressure gauge that is used to monitor the pressure of the Feed Water entering the ETD.
4. High Pressure Hose, ETD Outlet port "HP OUT" transfers pressurized Feed Water from the ETD to the inlet of the RO Membrane Element.
5. RO Membrane Element and Pressure Vessel allows potable water molecules to pass through while rejecting the salt ions. Only 13% of the Feed Water becomes Product Water. The remainder (concentrated brine) transfers energy back into the ETD.
6. High Pressure Hose - MVA Outlet / ETD Return port “HP IN” transfers pressurized Brine Water from the Membrane Vessel Assembly back to the ETD. This pressurized water assists the ETD as recovered energy. This allows the ETD to deliver the required flow and pressure to the RO Membrane Element with minimal power consumption.
7. ETD Outlet Port "LP OUT" takes the de-pressurized concentrated brine out to brine discharge.

Brine Discharge Components

The Brine Discharge section of your System transfers brine exiting the ETD back to the Feed Water source.

1. Brine Discharge Connector allows for the Brine Discharge Hose to connect to the Thru Hull Over Board Discharge Fitting.
2. Thru Hull Discharge Fitting** should be installed above water level for discharge of the Brine Discharge Water from the System.

Product Water and Post-Filtration Components

This section collects the product water as it exits the RO Membrane Element. The product water is tested for quality at the salinity probe, enters a 3-Way Product Water Diversion Valve, and then is measured for flow. When the Product Water Salinity decreases to the “safe” level, it is then diverted into the Post Filtration components, which are the final steps in Product Water quality control.

1. Product Water Manifold allows transfer of product water flow through the components attached to it.
2. Temperature Compensated Salinity Probe electronically determines whether the salinity content of the Product Water has decreased to the “safe” level. This Salinity Probe retains an accurate reading throughout varying temperature ranges.
3. 3-Way Product Water Diversion Valve, Electric Solenoid Actuated. The Salinity Controller energizes this valve to the “Potable” position when the System produces water, which meets the low salinity requirement. If the Product Water being produced is “un-potable” or high in salinity, then no signal is sent to the valve and it remains in the normally open position. The “fail safe” normally open position diverts the un-potable Product Water to discharge through the Brine Discharge Tee Connector.
4. Flow Meter, Product Water measures the rate of Product Water flow in gallons per hour from the RO Membrane Element.
5. Charcoal Filter is designed to remove foul odors from the Product Water. Sulfurous smell (rotten egg smell) is caused by decaying biological matter in the Feed Water chapter. Fresh water flushing of the System helps to minimize the source of this odor.
6. pH Neutralizer Filter*** The Product Water produced by Reverse Osmosis is slightly acidic. The pH Neutralizer Filter neutralizes the pH of the Product Water.
7. UV Sterilizer*** sterilizes up to 99.9% of viruses, bacteria and other micro-organisms that may pass through the RO Membrane Element. The UV sterilizer is recommended if the Product Water Storage Tank is not treated by chlorination, etc.
8. Potable Water Storage Tank Tube Connector is used to connect the Systems Potable Product Water output to the Potable Water Storage Tank.
9. Potable Water Storage Tank** may be any container suitable for storing Potable Water.

Fresh Water Flush and RO Membrane Element Cleaning

The Fresh Water Flush rinses the high salinity Feed Water from the System with Fresh Water. This process is automatic at each shut down of the System and repeats automatically every 7 days. Fresh Water Flushing replaces the seawater in the System with less corrosive fresh water. This reduces the biological growth that naturally occurs if the Feed Water (sea water) is left to stand in the System. Optional, manually operated valves are also available for ease of rinsing and cleaning the RO Membrane Element.

1. Fresh Water Flush Pump, included with the Fresh Water Flush Assembly. The Fresh Water Flush Pump draws fresh water from the Potable Water Storage Tank and pushes the water, at 45 PSI, through the Fresh Water Flush Charcoal Filter and into the rest of the System.
2. Fresh Water Flush Carbon Filter, included with the Fresh Water Flush Assembly. The Carbon Filter removes particulate matter and chlorine from the fresh water to prevent chlorine attack to the RO Membrane Element.
3. Fresh Water Flush Check Valve, included with the Fresh Water Flush Assembly. The Check Valve routes the fresh water to the System and prevents the fresh water from expelling out the Inlet Thru Hull Fitting.
4. Inlet Rinse Clean Valve*** used in conjunction with the Discharge Rinse Clean Valve simplifies the storage and cleaning procedures by allowing the operator to turn a valve rather than disconnect a hose. Also used for a manual fresh water flush if the Automatic Fresh Water Flush System is not installed.
5. Discharge Rinse Clean Valve*** used in conjunction with the Inlet Rinse Clean Valve simplifies the storage and cleaning procedures by allowing the operator to turn a valve rather than disconnect a hose.
6. Rinse/Clean Solution Container** used to hold rinse water, storage solution, winterization solution, or cleaning solution may be any 5 gallon or larger container (portable or permanently installed).

Electronic Components

The System’s electronic components measure water quality, control the direction of Product Water flow, Start and Stop the System, and contain the central electrical connection point. They also ensure only potable Product Water passes into the Product Water Storage Tank.

1. Salinity Controller monitors the salt content of the product water via the Salinity Probe, and signals the 3-Way Product Diversion Valve when Potable Water is being produced. The 3-Way Product Diversion Valve, Booster Pump Motor, Remote Control, UV Sterilizer, and Soft Motor Starter are each governed by this Controller. This enclosure also contains the high-voltage components of the system. It serves as the connection point for all the electrical systems such as the motors, switches, and valves.
2. Remote Controller*** allows for remote monitoring and controlling of the system.

Plumbing Connections

1. Tube-Fitting Connections and Assembly:
 - a) Cut tube end square and clean.
 - b) Loosen nut on fitting three turns.
 - c) Wet the end of the tube and insert tube into fitting until it bottoms. Loosen nut completely and remove tube with attached parts from body. Check to ensure that the O-ring is seated onto the tube under the spacer (and not pinched into the body). Insert tube with attached parts into the body and tighten nut finger-tight.



DWG #B00480XXX-A1

2. Refer to the illustration below. Always allow slack in all tube and hose lines. Never cause the tube or hose to immediately bend from the fitting. Allow the line to enter or leave from the fitting in a straight manner for several inches to ensure proper connection, to relieve stress to the fitting and tube or hose, and to allow ease of detachment and reattachment during maintenance or repair. If water lines are pulled tight causing them to bend at the fitting, they will leak, allow air to enter, fail prematurely and/or break the fitting that they are attached to.

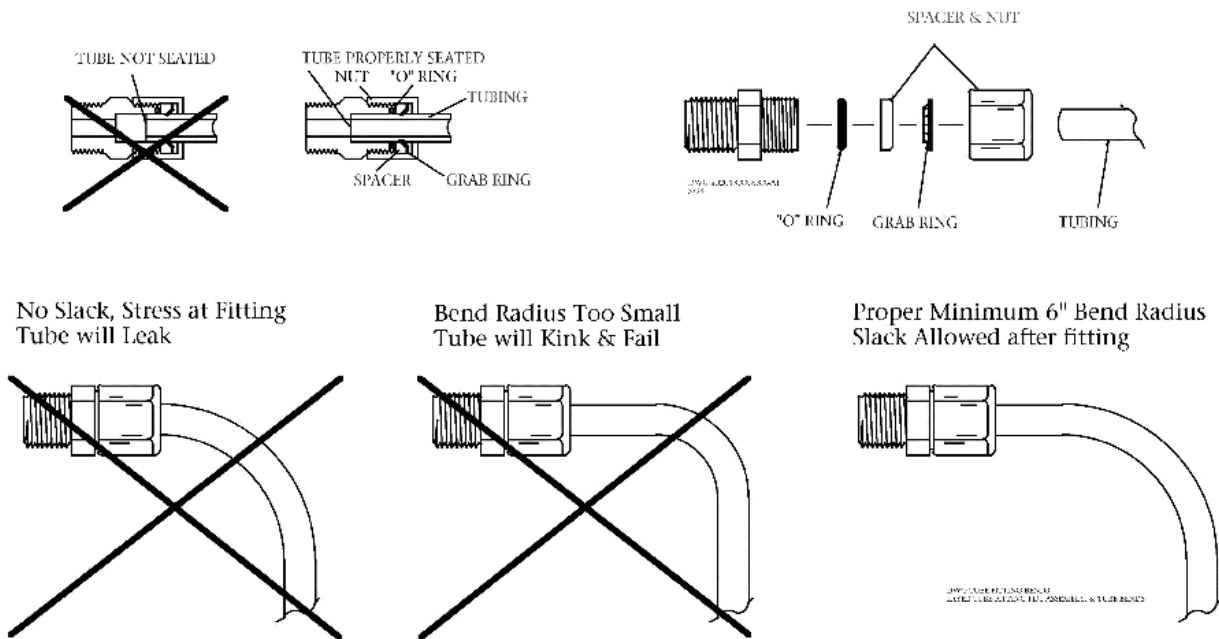

3. Ensure all suction hose connections use two hose clamps rotated 180 degrees with the screw heads facing the same direction. Remove any flash on the hose-barb fittings using fine sandpaper.

No Slack, Stress at Fitting
Hose will Leak

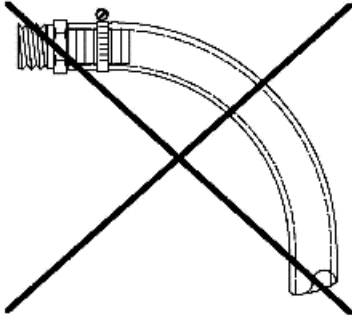

Bend Radius Too Small
Hose will Kink
Hose will Leak with One Clamp

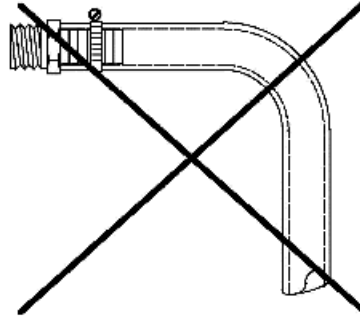

Proper Minimum 6" Bend Radius
Slack Allowed after fitting
Two Hose Clamps Offset

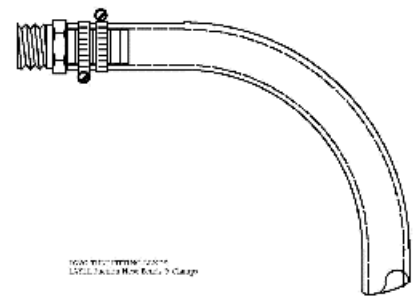

4. Ensure all high-pressure hoses have sufficient slack and are not pulled tight into a sharp or immediate bend.

No Slack
Stress at Fitting

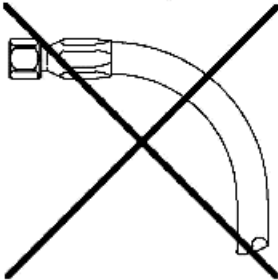

Bend Radius Too Small
Hose Will Kink and Burst

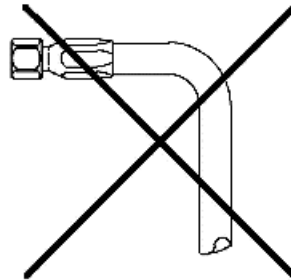

Proper Minimum 6" Bend Radius
Slack Allowed after fitting

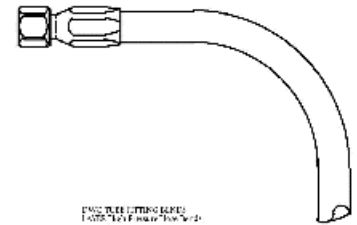

Chapter 5

Pre-Installation Safety

Ensure that you—as the Installer, Operator or both—read and understand the prerequisites, warnings and important notes within this topic.

Storage Prior to Uncrating

You must adhere to the following crate markings:

- **DO NOT** store in direct sunlight
- **DO NOT** store above 120°F (50°C)
- **DO NOT** allow the System to freeze (do not store below 32°F (0°C))
- **DO NOT** store longer than four (4) months without flushing with storage chemical
- Store only on base with **ARROWS UP**
- Keep the RO Membrane Element wet at all times

Uncrating

- **DO NOT DISCARD ANY PACKAGING UNTIL YOU HAVE FOUND AND IDENTIFIED ALL PARTS!**
- Remove the Seafari Quest system from the shipping carton. Note that some of the components are loose and/or separately packaged in the shipping container.
- Refer to the Illustrated Packing List pages to identify and confirm the contents of the Shipping Crate.
- **USE CAUTION WHEN TROUBLESHOOTING. DO NOT PERFORM MAINTENANCE UNLESS THE FOLLOWING CONDITIONS ARE MET:**
 - The System Feed Water Sea Cock Valve is closed.
 - The system main electrical disconnect switch is switched OFF, LOCKED, and TAGGED.
- **CAUTION: ELECTRICAL SHOCK HAZARD!** A Volt / Ohm Meter will be necessary. The Installation procedures expose the Installer to High Voltage and electrical shock hazard. Only attempt this if you are a qualified electrician and only if surrounding conditions are safe.

Tools required for Installation

Not all installations are typical; therefore, it is recommended to have a full set of Mechanic's, Plumber's, and Electrician's tools available. No special system tools are required for installation. A separate TDS Meter, available from Horizon Reverse Osmosis, will assist in confirming System product water quality. A volt/ohm meter (VOM) is required for system installation and commissioning to ensure proper electrical power and connection.

Chemical Precautions

-  **Danger:** The RO Membrane Element is susceptible to chemical attack. Take extreme caution in handling and storing! Do not expose your Seafari Quest RO Desalination System to feed water containing chemicals not approved in writing by Horizon Reverse Osmosis.

Do not connect a water line to your *Seafari Quest RO Desalination System* that may contain any of the following chemicals:

- Hydrogen peroxide chloramines-T

- Chlorine dioxide chlorine
- Bromine phenolic disinfectants
- Chloramines N-chloroisocyanurates
- Hypochlorite iodine
- Bromide petroleum products

 **Important:** The use of non-authorized and/or the misuse of authorized chemicals will void your Horizon Reverse Osmosis warranty! For example, DO NOT connect the System's inlet to your ship's potable water system if it contains chlorinated or brominated water. These chemicals destroy the copolymer components and the oxidants will damage the RO Membrane Element. In this situation, you can use the optional Horizon Reverse Osmosis Fresh Water Flush Accessory to remove the chlorine and bromine from your ship's potable water system before connecting the Seafari Quest RO Desalination System.

System Safety Check

 **Danger:** Do not perform installation, maintenance or troubleshooting procedures until you have verified the conditions below.

- The System's Feed Water Sea Cock Valve is closed.
- The System's main electrical disconnect switch is **OFF, LOCKED** and **TAGGED**.

Installer Minimum Qualifications

The System's Installer must have technical expertise in the following areas:

- Electrical, Electronic, Electric Motors and Circuits
- Electromechanical and Mechanical Systems
- Hydraulic and Liquid Pressure and Flow Systems
- Piping and Plumbing Systems
- Water Suction and Pressure Lines
- Thru-Hull Fitting below and above water level

Warnings





 **Danger: ELECTRICAL SHOCK HAZARD!** The Seafari Quest RO Desalination System installation procedures expose the installer to high voltage and potential electrical hazards. Technicians should only attempt installation if (1) they are qualified electricians and (2) surrounding conditions are safe.

 **Caution:** Do not attempt Installation, commissioning, troubleshooting, or repair of the Seafari Quest RO Desalination System unless you are proficient in the fields/functions listed within the chapter Installer Minimum Qualifications.

 **Caution:** The RO Membrane Element is stored in sodium bisulfite. Avoid skin and eye contact with this packaging solution. If skin contact occurs, rinse skin thoroughly with water. If eye contact occurs, flush eyes repeatedly with water and notify a physician immediately.

 **Caution:** Never mount the liquid holding component above any electrical or electronic device. Extensive damage to the electronic device will result if liquid enters device during maintenance and/or component failure.

 **Important:** Do not over-tighten PVC fittings. If threaded pipe fittings leak after installation, remove the fitting, clean the mating threads, apply three (3) to four (4) wraps of Teflon tape to the male threads, apply liquid Teflon pipe sealer sparingly, and thread the parts back together. PVC fittings should be hand tightened, without the use of a wrench.

-  **Important:** The Sea Cock Valve, Inline Pressure Gauge, Sea Strainer, Rinse Clean Inlet Valve, and Booster Pump should be installed below water level. This will aid the Booster Pump in priming.
-  **Important:** Always allow hoses and tubes to enter and exit straight from the connection for a minimum of 1 in. prior to a bend. If stress is placed on the fitting due to a tight bend, the fitting will leak and may break.
-  **Important:** All connection lines should be as short and straight as possible using minimum fittings. Ensure that they are not “kinked.”
-  **Important:** Ensure that the power source is sufficiently sized to provide the correct voltage and cycles during System start up and operation.
-  **Remember:** Install the system and its supporting components in an accessible manner.

Special Considerations

Length of Connection Lines

- All connection lines should be as short and straight as possible using minimum fittings.
 - Increased length causes vacuum and line-loss in the Suction chapter of the Feed Water line.
 - Increased length causes pressure loss in the Pressurized chapter of the Feed Water line.
 - Increased length causes excessive pressure build up in the Brine Discharge line.
 - Increased length causes excessive pressure build up in the Product Water line.
- The connection lines must not be kinked.
 - Kinks in the Feed Water line cause Booster Pump cavitation and continual System shut down.
 - Kinks in the Pressurized chapter of the Feed Water line cause excessive pressure build up and damage, as well as loss of required pressure to the ETD.
 - Kinks in the Brine Discharge line cause excessive pressure build up and damage.
 - Kinks in the Product Water line cause excessive pressure build up and damage.

Accessibility

- Install the system and supporting components in an accessible manner. The Seafari Quest System requires regular operator maintenance such as filter element changing. As with any Electro Mechanical system utilized in the Marine environment, the Seafari Quest System will require repair from time to time. Hidden or out of reach items may become forgotten, not maintained, and cause damage to other system components.
- The Electrical Control Panel Touch Pad must be accessible for operation of the System.
- The ETD and RO Membrane Element Pressure Vessel must be accessible for Membrane Element cleaning, rinsing, storing, and winterizing.
- Sea Strainer, Prefilters, Charcoal Filter, and pH Neutralizer must be accessible for user changing.

Components Supplied by the Installer or Owner

-  **Caution:** All fittings, valving and piping installed prior to, within, and after the Horizon Reverse Osmosis System must not contain iron; they must be non-ferrous material (not containing iron). Iron fittings or piping will cause rust fouling and failure of the RO Membrane Element. The resulting failure of the RO Membrane Element is attributed to improper installation, is the liability of the installer and is not covered by the Horizon Reverse Osmosis Warranty.

Water Connections for Seafari Quest Hook up to be Supplied by the Installer

1. Feed Inlet: 5/8” MNPT Male National Pipe Thread U.S. Standard
2. Brine Discharge: 3/8” MNPT Male National Pipe Thread U.S. Standard

3. Product: 1/4" FNPT Female National Pipe Thread U.S. Standard

Inlet Thru-Hull Fitting with Forward Facing Scoop

The inlet thru-hull fitting must be dedicated to only the Horizon Reverse Osmosis System. It is important that the installer utilizes a forward facing scoop so that the system receives a positive flow of water while the boat is underway. The fitting must be installed on the boat's hull in a position that provides continual feed water flow without air to the system.

-  **Caution:** A flat or flush inlet thru-hull fitting will cause a vacuum as the boat is under way and this will cause loss of feed water flow and cavitation of the booster pump resulting in continual System shut down due to low feed water flow and pressure. The resulting failure of the System to remain in operation is attributed to improper installation, is the liability of the installer, and is not covered by the Horizon Reverse Osmosis warranty.

-  **Caution:** If the thru-hull fitting is placed in a position that allows air to continually enter the thru-hull fitting this will cause the system to continually shut down due to loss of feed water. The resulting failure of the System to remain in operation is attributed to improper installation, is the liability of the installer, and is not covered by the Sea Recovery warranty.

-  **Caution:** The Horizon Reverse Osmosis System must not be tied into another existing auxiliary water line already supplying another accessory on the boat. Connecting the Horizon Reverse Osmosis System into a thru-hull fitting already supplying other equipment will cause the Horizon Reverse Osmosis System to draw air or cavitate leading to continual system shut-down or may starve the other equipment.

-  **Caution:** If the Horizon Reverse Osmosis System is connected to a Sea Chest or Stand Up Pipe, DO NOT plumb the Horizon Reverse Osmosis System feed line to the "top" of the Sea Chest or Stand Up Pipe. If plumbed into the top of these feed water arrangements, the Horizon Reverse Osmosis System will experience continual shut-down due to air inducement into the system. Plumb the Horizon Reverse Osmosis System to the "bottom" of such feed water arrangements to ensure a continual air-free supply of feed water to the system.

The resulting failure of the system to remain in operation due to any of the above improper installation is the liability of the installer and is not covered by the Horizon Reverse Osmosis Warranty.

- Inlet Sea Cock Valve quarter-turn ball valve min. 1/2" size, with a 1/2" MNPT connection for mating to the supplied 1/2" FNPT fitting.
- Brine Discharge Thru-Hull Fitting minimum 1/2" size with a 1/2" MNPT connection for mating to the supplied 1/2" FNPT fitting. The Brine Discharge Thru-Hull Fitting should be installed above water level. No valves should be installed in this line. Damage to and failure of the system due to a closed valve will not be covered by the Sea Recovery Warranty.
- Connection of the Potable Water Storage Tank Tube Connector to the boat's Potable Water Storage Tank requires a 1/4" FNPT connection for mating to the supplied 1/4" MNPT fitting. In order to avoid problems such as reverse flow (osmosis) from the tank to the system and chlorination attack of the RO Membrane Element, the fitting must terminate above the maximum water level. Tying into the tank fill line is a good choice. No valves should be installed in this line. Damage to and failure of the system due to a closed valve will not be covered by the Horizon Reverse Osmosis Warranty.
- Connection of the Sea Recovery Freshwater Flush subassembly to the boat's unpressurized potable water line requires a 1/2" FNPT connection for mating to the 1/2" MNPT fitting supplied with the Freshwater Flush subassembly.
- Circuit Breaker with appropriate amperage rating.
- Properly-Sized Power Cables.
- An electrical power source capable of delivering the required constant voltage and cycles during start-up and operation of the system.

Chapter 6

Installation

System and Component Mounting

The following instructions discuss the placement and mounting of the Seafari Quest Compact and Modular system components. If an optional accessory has not been included in your system, then please ignore that step and move to the next.

 **Caution:** Mounting surfaces must be flat in order to avoid warping of brackets and frames. Use appropriate shims on uneven surfaces to ensure that mounting of the system components does not cause bending or warping, and subsequent leaking or breakage. Damage to any system component due to attachment to uneven surfaces is the responsibility and liability of the installer and is not covered by the Horizon Reverse Osmosis Warranty.

- **ATTACHMENT:** All individual components are supplied with common mounting hardware. Some installations may require different hardware than what has been supplied.
 - **SUPPLIED HOSE AND TUBE LENGTHS:** When planning out the location and mounting of the system and related components, give consideration to the length of hose and tube supplied with the system.
1. Attach the supplied Feed Water Connector Assembly, 1/2 " FNPT elbow with attached 1/2" hose barb, to the boat's Sea Cock 1/4 turn ball Valve. Position the Outlet Hose Barb toward the Sea Strainer Inlet.
 2. Attach the supplied Brine Discharge Tee Connector Assembly, 1/2 " FNPT elbow with attached 1/4" Tube Fitting to the boat's overboard discharge fitting. Position the Inlet Tube Fitting toward the System Brine Discharge.
 3. Attach the supplied Potable Water Storage Tank Tube Connector 1/4" MNPT x 1/4" Tube Fitting to the 1/4" FNPT tap at the Potable Water Tank. The product water line may also be attached to the potable water storage tank fill line rather than drilling and tapping into the top of the tank itself.

 **Caution:** Do not use water tank diversion valves in this line to fill more than one tank. If it is absolutely necessary to use a diversion valve to fill more than one tank, use only a "never-closed"-type ball valve, which allows water to flow regardless of the valve handle position. If a valve in this line is closed during operation, extensive damage to the system will occur. Damage caused to the system due to installation of valves in the product water line is the responsibility and liability of the installer and is not covered by the Horizon Reverse Osmosis Warranty.

4. The Sea Strainer is mounted in an accessible location below water level between the Inlet Sea Cock Valve and Booster Pump. Allow at least 4 inches (10 cm) of clearance below the bowl to access the mesh screen for cleaning or replacement.
5. The ***Inlet Rinse Clean Valve is mounted in an accessible location below water level between the Sea Strainer Outlet and the ***Fresh Water Flush Check Valve Inlet if used, otherwise the Booster Pump Inlet.
6. The Booster Pump is mounted at or below water level to assist the pump in priming. Mount the Booster Pump between the Sea Strainer Outlet and the ***Plankton Filter Inlet if used, otherwise the Prefilter Inlet. It is best to mount the Booster Pump below water level to assist priming and in an accessible location to allow access for maintenance.

 **Caution:** Do not mount the pump head vertically above the motor, as motor damage will occur if the pump or its fittings should develop a leak. Eventually, the pump seal will wear and leak from use requiring replacement. Water damage to the motor, if mounted improperly, is the responsibility and liability of the installer and not covered by Horizon Reverse Osmosis Warranty

 **Caution:** Mounting of the Booster Pump above water level will cause a vacuum at the inlet of the pump and will result in premature wear resulting from cavitation. Improper installation of the Booster Pump causing excessive vacuum at the inlet of the pump resulting in cavitation and premature wear is the responsibility and liability of the installer and not covered by the Horizon Reverse Osmosis Warranty.

7. The ***Freshwater Flush Filter Canister with attached Flush Pump is mounted in an accessible location to a vertical surface between an unpressurized line in the potable water system and the Freshwater Flush Check Valve. Allow at least 4 inches (10 cm) of clearance below the bowl for element replacement.

 **Caution:** Potable water may spill during filter element replacing. Therefore, do not mount the Prefilter above any electrical or electronic component.

8. The ***Freshwater Flush Check Valve Assembly is mounted vertically in close proximity to the outlet of the Feed Water Pump and the inlet of the Plankton Filter or 25-micron Prefilter.

9. The ***Plankton Filter is mounted in an accessible location to a vertical surface between the Booster Pump Outlet and the Prefilter Inlet, which is mounted to the system frame. Allow at least 4 inches (10 cm) of clearance below the bowl for element replacement.

 **Caution:** Feed water may spill during filter element replacing. Therefore, do not mount the plankton filter above any electrical or electronic component.

10. The Prefilters are mounted to the system frame. They may be removed from the system frame and mounted separately in an accessible location to a bulkhead. Allow minimum 4 inches (10 cm) below the bowl for filter element removal.

 **Caution:** Feed water may spill during filter element replacing. Therefore, do not mount the Prefilter above any electrical or electronic component.

11. The system frame is mounted in an accessible location to a flat surface allowing ease of access to controls and for maintenance.

12. The Charcoal Filter is mounted in an accessible location to a vertical bulkhead. Allow minimum 4 inches (10 cm) below the bowl for filter element removal.

 **Caution:** Product water may spill during filter element replacing. Therefore, do not mount the charcoal filter above any electrical or electronic component.

13. The ***pH Neutralizing Filter is mounted in an accessible location to a vertical bulkhead after the Charcoal Filter and prior to the UV Sterilizer.

 **Caution:** Product water may spill during filter element replacing. Therefore, do not mount the pH Neutralizing Filter above any electrical or electronic component.

14. The ***UV Sterilizer is mounted to a bulkhead directly after the Charcoal Filter, or after the pH Neutralizing Filter if used. The UV Sterilizer should be mounted vertically with the electrical fitting on the top. The UV should be plumbed with the inlet on the bottom and the outlet on top. Horizontal mounting is acceptable with outlet port on top (pointed up) to displace air. Do not mount the UV Sterilizer with the electrical fitting on the bottom.

15. The ***Discharge Rinse Clean Valve is mounted in an accessible location between the System Brine Discharge Outlet and the Brine Discharge Thru-Hull Fitting. Mount this valve in an accessible location.

16. The ***Remote Controller is mounted to a flat surface with appropriate cut out for flush mounting to the flat surface. Mount the Remote Controller in a protected area away from water spray.

Electrical Connections

1. Remove the front cover from the system controller to access the Main Terminal Strip and PC Board.

2. Connect main power using cable recommendations. The main power cable is inserted through one of the large strain reliefs on the side of the controller enclosure.
3. Connect the Booster Pump motor power through the other large strain relief on the side of the controller enclosure to terminals.
4. Connect the Freshwater Flush (FWF) Boost Pump using the supplied cable. Loosen the FWF strain relief on the controller enclosure and insert the cable.
5. Connect UV Sterilizer using supplied purple cable. Loosen the other small strain relief on the side of the controller enclosure and insert the purple cable. Connect to the PC Board.

Hose Lines

REJECT WATER 5/8" HOSE LINE

Use the 5/8" braided hose to connect the 1/2" hose barb on the ETD outlet labeled "S" to the 1/2" hose barb on the Reject Water Assembly. The Reject Water Assembly should be connected to the Thru-Hull Discharge Fitting.

PRODUCT LINES - 1/4" BLACK TUBE

Use the 1/4" black tube to connect the tube connection on the bottom of the Product Manifold to the tube connection on the Membrane Vessel Assembly. Use the 1/4" black tube to connect the tube connection on top of the Product Manifold to the tube connection on the boat's product tank.

REJECT LINES - 1/2" BLACK TUBE

Use the 1/2" black tube to connect the tube connection on the bottom of the Product Manifold to the tube connection on the Reject Water Assembly.

FEED WATER 5/8" HOSE LINE

Use the 5/8" braided hose to Connect the 1/2" hose barb on the 3/4" Inlet Elbow Assembly to the Sea Strainer inlet. Always use two 3/4" hose clamps when assembling the 5/8" braided hose. Connect the outlet of the Sea Strainer to the Booster Pump then to the check valve assembly inlet. Connect the check valve assembly outlet to the high pressure inlet. Connect the high pressure outlet to the prefilter inlet Tee.

Required Hose and Tube Connections

** = Supplied by Installer or Owner

*** = Optional Accessory

1. Connect Feed and Freshwater Flush Lines with the supplied 20 feet (6 meters) of 1/2" (12.7 mm) I.D. Inlet Suction Hose. Secure the hose with two hose clamps offset 180 degrees at each fitting. Ignore any optional accessory that is not to be installed:

Step	from Outlet of:	to Inlet of:
1.	Feed Water Connector	Sea Strainer
2.	Sea Strainer	***Inlet 3-Way Clean/Rinse Valve (left or right port)
3.	**Rinse/Clean bucket or container	***Inlet 3-way Clean/Rinse Valve (left or right port)
4.	***Inlet 3-way Clean/Rinse Valve (center port)	Booster Pump
5.	Booster Pump	Freshwater Flush Check Valve
6.	Freshwater Flush Check Valve	***Plankton Filter
7.	***Plankton Filter	Prefilter 25 micron

Step	from Outlet of:	to Inlet of:
8.	**Unpressurized Potable Water Tank Line	Freshwater Flush Pressure Pump
9.	Freshwater Flush Carbon Filter	Freshwater Flush Check Valve

2. Connect Brine Discharge Line with the supplied 20 feet (6 meters) of 3/8" (9.5 mm) O.D. Brine Discharge Tubing:

Step	from Outlet of:	to Inlet of:
1.	ETD located inside the system frame	***Discharge Rinse Clean Valve (center port)
2.	***Discharge Rinse Clean Valve (left or right port)	**Rinse Clean bucket or container
3.	***Discharge Rinse Clean Valve (left or right port)	Brine Discharge Connector

3. Connect Product Water Line with the supplied 30 feet (9.14 meters) of 3/8" (9.52 mm) O.D. nylon tubing:

Step	from Outlet of:	to Inlet of:
1.	Product Water Manifold Port "B" Unpotable located inside the system frame	Brine Discharge Tee
2.	Product Water Manifold Port "A" Potable located inside the system frame	Charcoal Filter
4.	Charcoal Filter	***pH Neutralizing Filter
5.	***pH Neutralizing Filter	***UV Sterilizer
5.	***UV Sterilizer	**Potable Water Storage Tank Connector

4. Connect Pressure pick-up with Pressure Gauges with the supplied 20 feet (6 meters) of 1/4" (6.35 mm) O.D. nylon tubing:

Step	from Outlet of:	to Inlet of:
1.	Booster Pump Pressure Pick Up Tee located on booster pump	Inlet Compound Vacuum/Pressure Gauge located inside the system frame

Ultraviolet (UV) Light Installation

The SP-Series UV unit is shipped with the UV lamp, quartz sleeve, fittings and O-rings and needs to be assembled before the UV unit can be used.

1. Install the UV unit in a sheltered, well-ventilated area.
2. Install the UV unit as close as possible to the point-of-use to avoid potential contamination discharge from pipes, fittings, etc.
3. The UV unit should be mounted on stable support to avoid straining or warping. Allow sufficient clearance around the unit for servicing.
4. Verify the location is free from vibration.
5. All UV units are rated for maximum operating pressure at 50psig (8.24 bar).
6. The UV unit must be properly grounded for safe and proper operation. Failure to properly ground the UV unit automatically voids all unit warranty.
7. Line voltage must be within 10.56V to 16.50V. Voltage outside the range will compromise the performance of the UV unit.

Plumbing Requirements

All piping, tubes and hoses leading to the UV unit connection points must be leak-free!

- ✓ **Note:** UV unit may be installed horizontally or vertically. For vertical installation, make sure the inlet port is positioned at the bottom.
- ✓ **Note:** Do not assemble or install damaged parts. Quartz sleeve and UV lamp are fragile and must be handled with care.

Install Fittings

Perform this procedure to prepare the UV unit for installation.

1. Inspect each port and fitting to ensure threads are free of dirt, burrs and excessive nicks. If threads are badly nicked, replace the fitting.
2. Wrap 3/8" wide PTFE tape 2 to 3 turns counterclockwise around the male threads of the 3/8" fitting. Do not wrap tape around the first thread.
3. Screw the fitting into cylinder ports to finger-tight position to achieve desired alignment.
4. Do not back off fitting. Do not over tighten fitting. Over tightening could strip the fitting threads and cause leak.

Install Quartz Sleeve

Perform this procedure only when water piping for UV unit is in place and ready for service.

1. Visually inspect quartz sleeve for cracks and damages.
2. Remove the four screws holding the ballast box cover and remove the cover.
3. Remove the rubber boot and pull out the 4-point lamp connector.
4. Remove the compression nuts.
5. Insert the close-end of the quartz sleeve into the cylinder through the ballast box pass-thru.
6. Allowing 2" of the quartz sleeve to expose on the viewport pass-thru.
7. Lubricate the tips of the quartz sleeve with clean water and insert new O-ring. Ensure the O-ring has all-round contact with the cylinder pass-thru.
8. Tighten the compression nut while making sure the nut does not contact the quartz sleeve. Adjust O-ring position as necessary. The compression nut should be snug and tight, do not over-torque.
9. Repeat Step 7 and 8 on the ballast box compression nut.

Connect Plumbing

Tube or hose ends must be cut squared and clean and have no rough edges. The quick fit elbow fitting has a C-clamp that will lock the tube in place once inserted.

1. Insert the supply pipe into one cylinder port and label the port "Inlet."
2. Insert the temporary pipe into the other cylinder port to direct water into a container.
3. Slowly fill the cylinder with water and flush cylinder for 1 minute.
4. Remove temporary pipe and insert the return pipe into the cylinder port and label the port "Outlet."
5. Slowly pressurize the UV unit by filling the cylinder with water while checking for leaks.
6. If leaks are found on the compression nuts, depressurize the unit and slightly tighten the leaking compression nut.
7. Retest until a leak-free installation is verified.
8. Once UV unit is leak-free, the quartz sleeve installation is complete and the UV lamp can be installed.

- ✓ **Note:** To remove tube from fitting, first remove the C-clamp then push fitting sleeve down. Once the fitting sleeve is down, pull the tube out of the fitting.

Install Lamp

Perform this procedure only after the quartz sleeve installation and leak-tests are completed successfully

1. Connect the UV lamp to the 4-point receptacle. If the lamp is not installed properly, lamp breakage will occur.
2. Insert lamp into quartz sleeve through compression nut pass-thru.
3. Install rubber boot over compression nut.
4. Connect unit power cable to power source.
5. Tighten the 4 screws to secure ballast box cover.
6. Turn ON the power to the unit.
7. Verify UV lamp operation from the viewport.
8. Allow one minute for the UV lamp to warm up prior to flowing water through the UV unit.

 **Caution:** Use the viewport to verify the proper operation of the UV lamp.

 **Caution:** Rapid successive cycling of the power to the ballast can cause premature failure of the unit.

 **Caution:** Prior to energizing the lamp, make sure there is no water leaking from the quartz sleeve compression nuts.

Mounting the Unit

Once the UV unit is assembled and tested successfully, it can be mounted onto its permanent operational location. The unit must be mounted in a manner that will prevent excessive vibration and warping which will damage the quartz sleeve.

Operational Notes

- Release the pressure in the UV treatment chamber before breaking the compression nut seals.
- Disconnect all power to the UV unit before servicing.
- Do not allow the inlet water temperature to drop below 35°F (2°C).
- Do not allow the flow rate to exceed 2 GPM.
- Do not cycle the UV unit more than 3 "ON/OFF" cycles in a 24-hour period.
- Ensure all plumbing connections are tightly sealed before applying pressure.
- Before connecting the return tube, flush the unit to rinse out any debris left from the installation process.

 **Danger:** UV LIGHT EXPOSURE CAN SEVERELY BURN AND DAMAGE EYES AND SKIN.

 **Danger:** DO NOT look at the blue UV light. DO NOT operate the UV lamp outside of the UV treatment chamber.

 **Danger:** The unit operates on high voltage and must be serviced by qualified personnel only.

 **Caution:** Standard flow rate are based on water temperature 35°F to 100°F. If the inlet water temperature exceeds 100°F (38°C), please contact your local CSR.

 **Caution:** Cycling more than 3 cycles will reduce the end-of-life (EOL) output and/or cause premature lamp failure.

Compact Installation Drawing

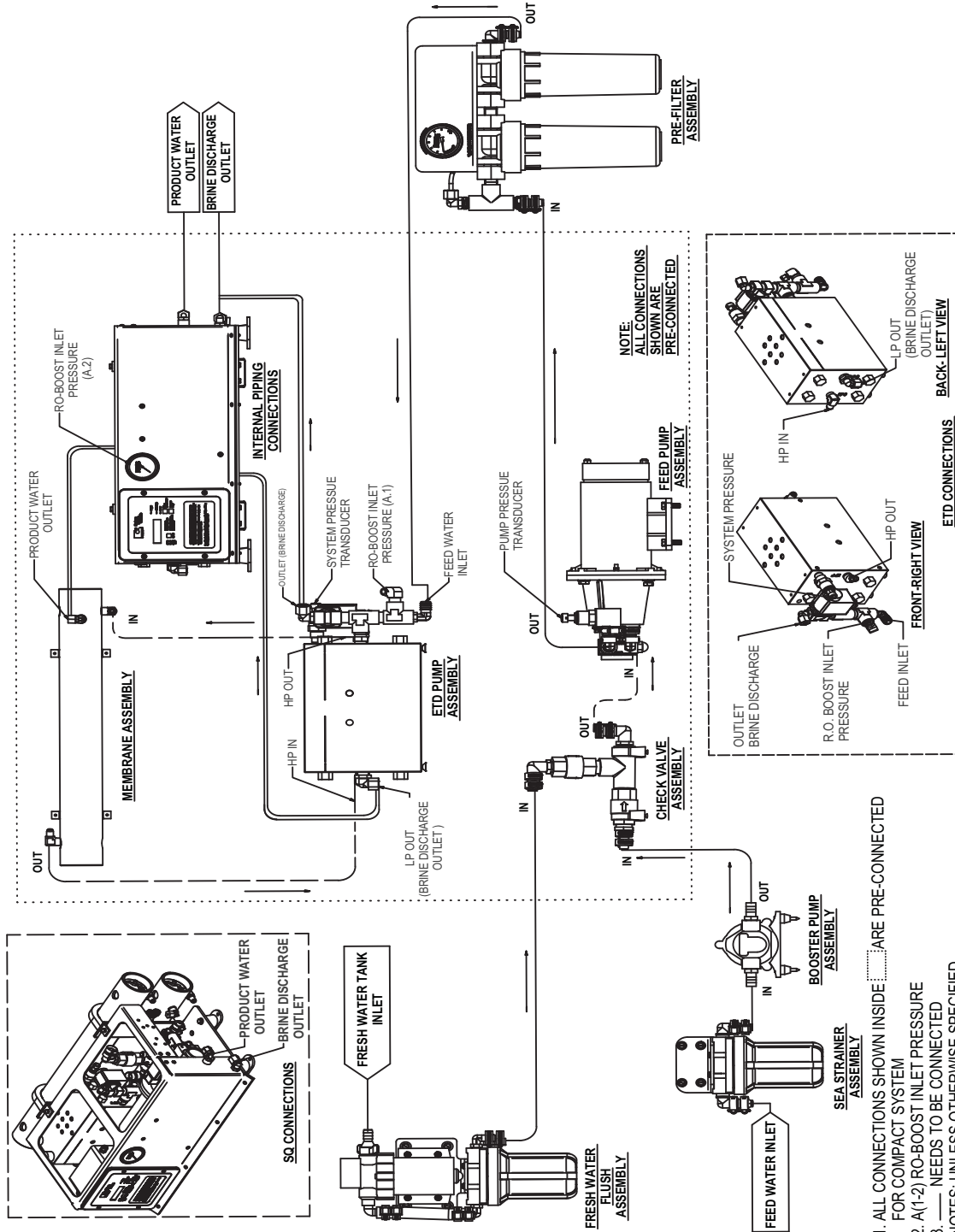

Modular Installation Drawing

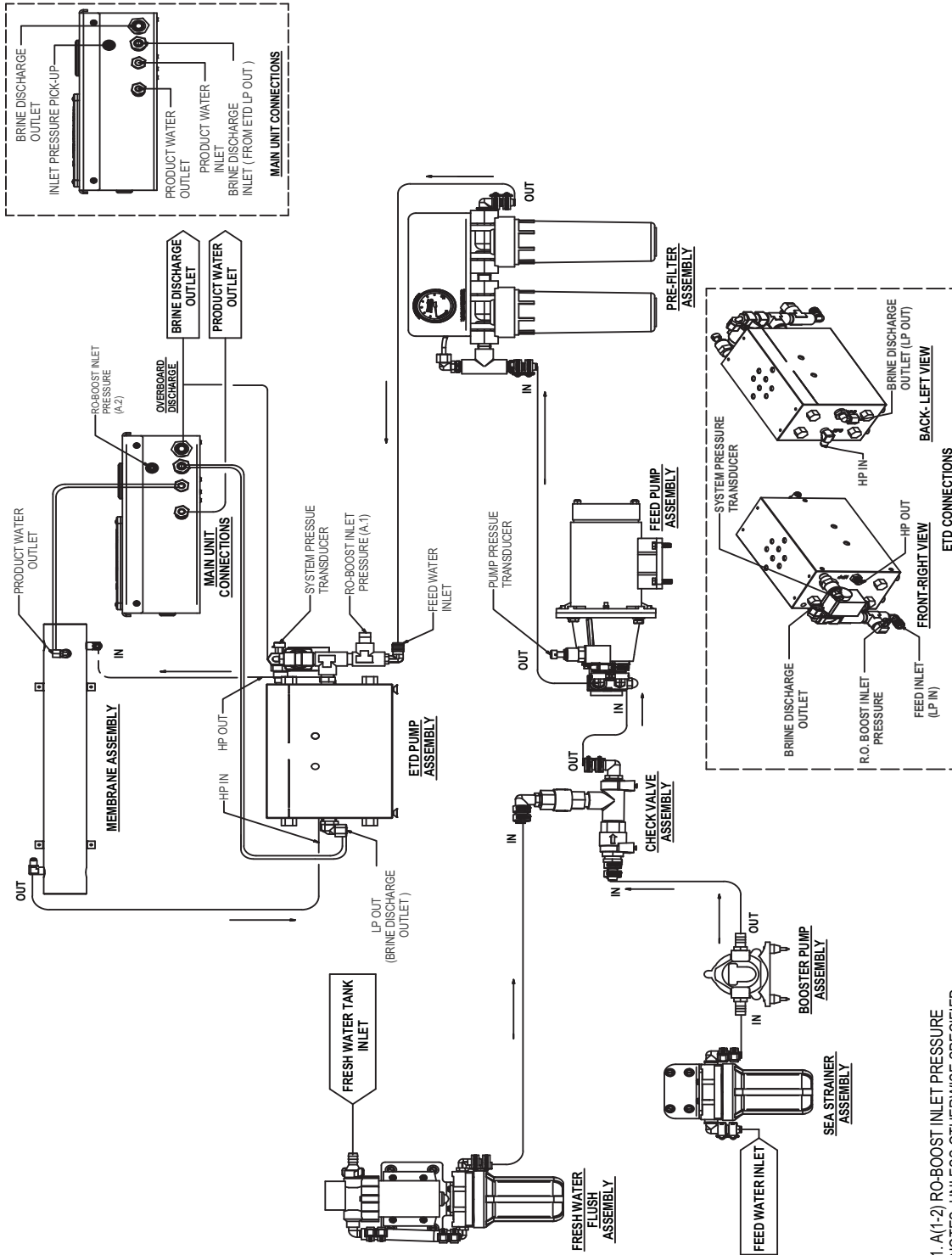

1. A(1-2) RO-BOOST INLET PRESSURE
 NOTES: UNLESS OTHERWISE SPECIFIED

Chapter 7

Commissioning a New System

New System Start-up Procedures

1. Ensure that the installation has been properly performed.
2. Ensure that the tube-shipment plug has been removed from the potable water outlet port of the Water Control Manifold (Compact System) or from the RO Membrane/Vessel Product Water Port (Modular System) and that all 1/4-inch and 3/8-inch product water tubes are connected.
3. Check the RO Membrane Element as described below.

 **Note:** Some systems are shipped WITHOUT the RO Membrane Element. This is to accommodate, for example, boat builders who install the system well in advance of commissioning the boat and the Horizon Reverse Osmosis System.

If the RO Membrane Element has been installed, there will be an Element Serial Number tag attached to the RO Membrane/Vessel Assembly. Find this serial number tag to ensure that the RO Membrane Element has been installed.

If the RO Membrane Element Serial Number tag is missing or does not contain a serial number and date, then immediately contact the company that sold the system to you or Horizon Reverse Osmosis. Provide Horizon Reverse Osmosis with the system serial number and model number of this Seafari Quest System.

 **Caution:** **DO NOT** attempt to operate the system without a RO Membrane Element installed in the system, as extensive damage will result.

4. Ensure that the manual bypass lever located on the side of the 3-Way Product Water Solenoid Diversion Valve is positioned outward (away from the coil body).
5. Check each hose and tube connection to the system to ensure that the installer has properly connected and routed each hose and tube. Ensure that there are no kinks or blockages in any of the hoses or tubes leading to and from the Seafari Quest System. Improper routing and any blockage in any line causes damage to the system. *Do not rely on the installer's word; check it yourself.*
6. Make sure that the electrical power source, the boat's circuit breaker, to the system is switched "OFF."
7. Open the front panel of the Main Power Enclosure. Check all electrical and electronic connections for proper wiring and attachment.
8. Ensure that the installer has used the proper-sized power wire and Booster Pump wire.
9. Close the Main Power Enclosure front panel.
10. Open the Sea Cock Valve.
11. Open any auxiliary valve within the incoming feed line, Outgoing Brine Discharge Line and Outgoing Product Water Line.

 **Caution:** Any auxiliary valve in these lines damages the Horizon Reverse Osmosis System if left closed during starting and/or operation of the system.

12. If the optional Clean Rinse Valves are installed, ensure that they are positioned properly for normal operation.
13. Switch the electrical power source to the "ON" position, the boat's circuit breaker.

14. Perform a booster pump motor rotational check. Ask an assistant to view the fan chapter of the Feed Water Pump Motor while “jogging” this electric motor.

Press the “START/STOP” switch; then immediately after the booster pump starts, press the “START/STOP” switch. Ensure that the Feed Water Pump Electric Motor is turning in the proper rotation.

To change rotation in DC systems, reverse polarity to the electric motor by interchanging the positive and negative power leads to the motor. Then check the rotation again to ensure proper rotation.

 **Caution:** The feed pump is a very close tolerance vane pump. It requires water for lubrication. Operating this pump dry will damage it within 30 seconds. Prime the system with water up to the booster pump inlet to ensure that it is wet prior to starting.

15. To start the system, press, the “START/STOP” switch. If the system automatically shuts off immediately or after 20 seconds of operation, this may be due to a system fault. Look at the controller to confirm whether a fault has occurred. If Error ID 2 or 3 (High/Low Pressure Error) appears on the screen, ensure that the system feed line is primed and that there is no air in the feed water line. Then restart the system. Initial new system commissioning may require priming of the feed water up to the Feed Pump inlet and through the pre-filtration in order to build sufficient feed water pressure to maintain operation. Refer to the Troubleshooting Section of this manual.
16. If there are no unforeseen abnormalities, the Seafari Quest System pressure will automatically increase to normal operating range immediately after starting. The ETD will increase pressure to a point at which the system produces the specified amount of product water. Please refer to “System Specifications” of this chapter for approximate expected pressures that a new system should develop when operating in typical sea water of 35,000 PPM TDS at 77 F / 25 C. If any abnormality develops, stop the system and correct the problem.
17. Although the system is producing “product water,” the “product water” may not be “potable” for up to 30 minutes. New RO Membrane Elements require operating time to flush storage chemical from the product water channel. Daily operation requires operating time to flush dissolved solids from the product water channel. The operating time required to flush the product water channel is normal for reverse osmosis systems.

The salinity of the product water diminishes gradually and is measured by the salinity probe. When the salinity of the product water has diminished to the factory setting, the salinity controller will energize the 3-Way Product Water Diversion Valve. At that instant, product water will be routed to the charcoal filter, pH neutralizer and UV sterilizer onward to the potable water storage tank.

18. Check for the following:
 - a) A constant feed water flow.
 - b) A consistent system pressure.
 - c) Leaks in the system.
 - d) Unusual noises or other occurrences.
19. Complete the “**NEW SYSTEM INITIAL READINGS**” form at the end of this chapter.
20. Prior to stopping the system, determine if the system will be stored for a period of time or if it will be turned over to the owner and operated regularly. Failure to properly flush and/or store the system will lead to premature fouling or drying out of the RO Membrane Element, which is not covered by the Horizon Reverse Osmosis Warranty and is the liability of the person commissioning the system.
 - a) If the system will be operated within the next two weeks, no action is necessary. However, if the system will be exposed to freezing temperatures, you must perform winterizing procedures. Freezing temperatures will cause extensive damage if the system is not properly protected.
 - b) If the system will not be operated within the next two weeks, perform a freshwater flush. If the Horizon Reverse Osmosis Automatic Freshwater Flush is installed, ensure that the potable water storage tank has potable water for the freshwater flush to utilize in rinsing the system. If the system does not include an automatic freshwater flush, then perform a manual freshwater flush.
 - c) If the system will not be operated within the next two months or longer, perform a long-term storage operation.
21. Stop the system by pressing the “START/STOP” button once. After a 90 minute delay period, the freshwater flush automatic cycle will begin, as indicated on the LCD Screen. The time delay is to allow the ETD to dissipate its pressure.

The freshwater flush pump is equipped with a pressure switch that will cycle the pump on and off. If the pump’s outlet pressure is below 45 PSI, the pump will operate; when the pump’s outlet pressure is above 45 PSI, the

pump will stop. The freshwater flush pump will cycle on and off during the freshwater flush cycle. This is normal and to be expected.

The freshwater flush cycle will last for approximately 10 minutes. The 10-minute cycle is adjustable. Every 7 days, the freshwater flush rinse cycle will repeat automatically.

If the "START/STOP" button is pressed twice, the automatic freshwater flush cycle will be cancelled.

22. Close the Inlet Sea Cock Valve. This is a safeguard for vessel installations.
23. If the freshwater flush is installed and activated, do not interrupt power. If the freshwater flush is not installed or is not activated, turn off the electrical power source (circuit breaker) to the system. This eliminates the chance of inadvertently starting the system. If the power source has been turned off, the freshwater flush will not cycle every 7 days.

Pressure Changes

The system operating pressure (the pressure applied to the RO Membrane Element) varies with the feed water temperature, the feed water salinity and the condition of the RO Membrane Element. The system design specifications are based on feed water temperature of 77° F / 25° C and a feed water salinity of 35,000 PPM-TDS (parts per million-total dissolved solids). Each RO Membrane Element can vary +/- 15%, which will cause the final operating pressure to decrease or increase accordingly. However, assuming the "perfect RO Membrane," at this temperature and salinity the system will operate at the standard system pressure listed within the specifications at the beginning of this Owner's Manual.

If the feed water salinity increases or if the feed water temperature decreases, the system operating pressure will increase. Inversely, if the feed water salinity decreases or if the feed water temperature increases, the system operating pressure will decrease. Furthermore, if the RO Membrane Element is new or old and fouled, the system operating pressure automatically decreases or increases accordingly to overcome the RO Membrane Element condition.

Operating amperage and operating pressure will increase if:

1. The feed water temperature is lower than 77° F / 25° C.;
2. The feed water salinity is greater than 35,000 PPM TDS (3.5% Total Dissolved Solids);
3. The RO Membrane Element becomes fouled;
4. The RO Membrane Element is new and on the minus 15% side of the specifications.

Operating amperage and operating pressure will decrease if:

1. The feed water temperature is higher than 77° F / 25° C.;
2. The feed water salinity is less than 35,000 PPM TDS (3.5% Total Dissolved Solids);
3. The RO Membrane Element is new and on the plus 15% side of the specifications.

By monitoring feed water salinity, temperature and resulting system operating pressure, it is possible to measure and monitor the fouling of the RO Membrane Element over time and use. As the feed water vane pump becomes worn from normal use, it will lose flow and the ability to build up pressure. A reduction in product water production could be caused by insufficient pressure and/or flow from the booster pump. Should the booster pump become worn resulting in reduced pressure and/or flow, it may be returned to Horizon Reverse Osmosis for rebuild or replacement. Because of the specific matching requirements of the wear parts and tight tolerance, it is not practical to repair in the field.

Horizon Reverse Osmosis Seafari Quest NEW SYSTEM INITIAL READINGS

At the time of commissioning the NEW system, record the following information after one hour of continuous proper operation of the system. Retain this form in the Owner's Manual for future reference and troubleshooting. This information is valuable to the servicing technicians in providing technical support to the owner and future operators of the Seafari Quest System. Provide this information to service technicians when requesting technical assistance.

Serial Number: _____

Check Model Number:

Seafari Quest Compact _____ 200; _____ 400; or _____ 600

Seafari Quest Modular _____ 200; _____ 400; or _____ 600

Name of Operator: _____

Date: _____

Installer Information:

Company _____

Street Address _____

City, State _____

Country, Postal Code _____

Telephone Number _____

Name of Installer _____

System Power: _____ Volts AC, _____ Hz or _____ Volts DC

Feed Water Temperature: _____ Fahrenheit or _____ Celsius

Hour Meter Reading: _____ Hours

PRESSURE GAUGE READINGS:

Booster Pump Inlet Vacuum/Pressure Gauge Reading: _____ - In Hg, or _____ PSI, or _____ Kg/Cm²

Prefilter Inlet Pressure Gauge Reading: _____ PSI, _____ Bar, _____ KPa, or _____ Kg/Cm²

ETD Inlet Pressure Gauge Reading: _____ PSI, _____ Bar, _____ KPa, or _____ Kg/Cm²

RO Membrane/Vessel Assy Outlet Pressure Gauge Reading:

_____ PSI, _____ Bar, _____ KPa, or _____ Kg/Cm

WATER FLOW METER READINGS:

Product Water Flow Meter: _____ US Gallons Per Hour, or _____ Liters Per Hour

WATER QUALITY:

Feed Water Salinity: _____ ppm or Location of Use: _____



Product Water Salinity: _____ ppm

Unusual Occurrences or Noises: _____

Chapter 8

System Daily Operation

Day-to-Day Start-up Procedures for the Seafari Quest System

1. Open any auxiliary valve within the incoming feed line, Outgoing Brine Discharge Line and Outgoing Product Water Line.
 -  **Danger:** Any auxiliary valve in these lines damages the Horizon Reverse Osmosis System if left closed during starting and/or operation of the system.
 -  **Caution:** In temperatures below 32° F/ 0° C, the freshwater will freeze and damage the components filled with freshwater. Do not operate the system in below-freezing feed water temperatures.
2. If the optional Clean Rinse Valves are installed, ensure that they are positioned properly for normal operation. Refer to the Piping and Interconnect Diagram at the beginning of this Chapter.
3. Open the Sea Cock Valve.
4. Switch the electrical power source to the “ON” position, boat’s circuit breaker.
 -  **Danger:** The booster pump is a very close tolerance vane pump. It requires water for lubrication. Operating this pump dry will damage it within 30 seconds. If feed water has drained from the pump, prime the system with water up to the booster pump inlet to ensure that it is wet prior to starting.
5. To start the system, press the “START/STOP” switch. If the system automatically shuts off immediately or after 20 seconds of operation, this may be due to a system fault. Look at the touch pad to confirm whether a fault has occurred.
6. If there are no unforeseen abnormalities, the Seafari Quest System pressure will automatically increase to normal operating range immediately after starting. Refer to temperature and salinity charts in the final chapter of this manual.
7. If any abnormality develops, stop the system and correct the problem.
8. Although the system is producing “product water,” the “product water” may not be “potable” for up to 30 minutes. The “Water Quality” lamp illuminates “red” if the product water is unpotable and “green” if the product water is potable. The salinity of the product water diminishes gradually and is measured by the salinity probe. When the salinity of the product water has diminished to the factory setting, the salinity controller will energize the “green” water quality lamp and the 3-Way Product Water Diversion Valve. At that instant, product water will be routed to the charcoal filter, pH neutralizer, UV sterilizer and onward to the potable water storage tank.
9. Check for the following:
 - a) A constant feed water flow.
 - b) A consistent system pressure.
 - c) Leaks in the system.
 - d) Unusual noises or other occurrences.

Controller Operations

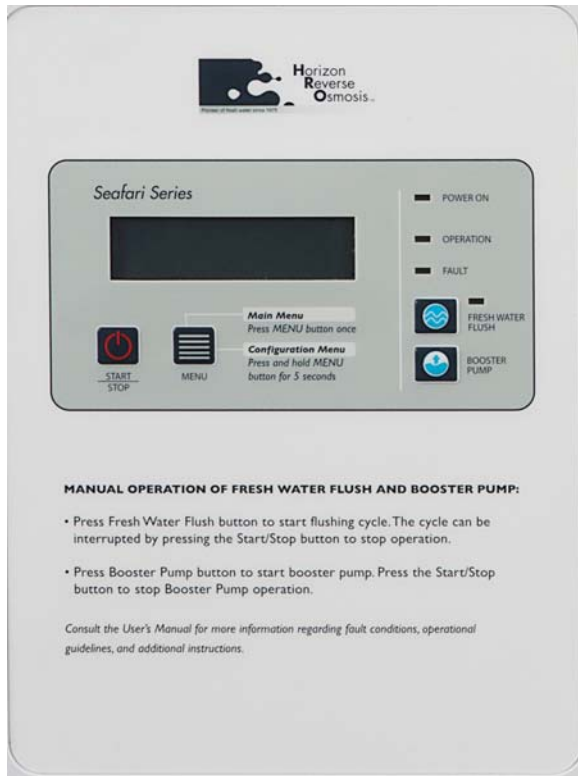

Start/Stop button

1. Powers on and sets the system in its initial state.
2. When the system is producing water and the START/STOP button is pushed, the system stops all pumps and diverts water into the sea.
3. Resets all faults.

Note that this button performs its designated action, regardless of whether or not you are browsing a menu.

Cycle button

This button allows the operator to cycle through the process and configuration parameters.

- Press the CYCLE button once to view to view the Display Menu.
- Press and hold CYCLE for 5 seconds to view the Configuration Menu.

Display Menu

This menu monitors measured values (e.g. pressure, flow and salinity); system states (e.g. FWF, running, FWP); and timers. Press the CYCLE button once to view this menu and CYCLE again to scroll through the menu items. Every time CYCLE is pressed, the next item is shown. If you release, and do not push the CYCLE button for more than 5 seconds, you will return to the main screen.

1. Pre-Filter Press – Inlet pressure in Bar or PSI (pre-filter inlet)
2. HP Inlet Press – Inlet pressure in Bar or PSI (high pressure pump inlet)
3. Membrane Press – Membrane pressure in Bar or PSI
4. Product Flow – Product water flow in l/min or GPM
5. Brine Flow – Brine flow in l/min or GPM
6. Water Quality – Salinity (water status) in ppm
7. Total Hours – High pressure pump/ETD hour meter (counted in seconds but shown in whole hours)
8. Tank Full – Yes or no

9. Tank Empty – Yes or no
10. Booster Relay - Booster pump on or off
11. FWF Relay – Fresh Water Flush on or off
12. HP Relay – High pressure pump on or off
13. DV Relay – Diversion valve on or off
14. UV Relay – Ultraviolet on or off
15. Supply Voltage – volts (used only for diagnostics)
16. Version – software version

Configuration (Change) Menu

This menu shows a list of configuration parameters that can be changed by the operator. Press the CYCLE button and hold for 5 seconds to view this menu and CYCLE again to scroll through the menu items. Every time CYCLE is pressed, the next item is shown. Holding the CYCLE button for more than 5 seconds selects the displayed menu item. Note that this menu does not allow the operator to monitor the state of these configuration parameters. Please use the Configuration (Read) Menu to do so.

1. Unit – units (metric or US)
2. Low Pressure 1 Inst – S1 Lo pressure sensor installed (yes or no)
3. Low Press 2 Inst – S2 Lo pressure sensor installed (yes or no)
4. Prod Flow Inst – Product flow meter installed (yes or no)
5. Brine Flow Inst – Brine flow meter installed (yes or no)
6. Tank Full Inst – Tank level full sensor installed (yes or no)
7. Tank Empty Inst – Tank level empty sensor installed (yes or no)
8. FWF Delay – High pressure pump stop to FWF delay (HH:mm:ss)
9. Time to AutoShut – Auto shutdown after X hours in state FWP (HH:mm:ss)
10. AutoShut Time – Auto shutdown after time (yes or no)
11. AutoShut Tank – Auto shutdown on tank full (yes or no)
12. FWF Duration – FWF duration time (HH:mm:ss)
13. FWF Interval – FWF interval time (HH:mm:ss)
14. PassiveUVoff – Time from leaving fresh water production to turning UV off (HH:mm:ss)
15. UV off delay – Time from UV on to diversion valve to tank (HH:mm:ss)
16. AutoStart Tank – Autostart on tank empty (yes or no)
17. BP Delay – Time from feed pump to high pressure pump/ETD (HH:mm:ss)
18. Salinity Level – Salinity error level (ppm)
19. Min Pressure – minimum pressure (Bar or PSI)
20. Min Pressure Time – Min pressure measure time (HH:mm:ss)
21. Max Pressure – Maximum pressure (Bar or PSI)
22. Sol. Valve Time – Solenoid valve time (seconds)

Configuration (Read) Menu

This menu monitors a selected list of configuration parameters, which may be of interest to the operator (e.g. units are metric or US, FWF time interval, etc.). This menu is appended to the Display Menu.

1. Unit – units (metric or US)
2. Low Pressure 1 Inst – S1 Lo pressure sensor installed (yes or no)
3. Low Press 2 Inst – S2 Lo pressure sensor installed (yes or no)
4. Prod Flow Inst – Product flow meter installed (yes or no)
5. Brine Flow Inst – Brine flow meter installed (yes or no)
6. Tank Full Inst – Tank level full sensor installed (yes or no)
7. Tank Empty Inst – Tank level empty sensor installed (yes or no)
8. Time to AutoShut – Auto shutdown after X hours in state FWP (HH:mm:ss)
9. AutoShut Time – Auto shutdown after time (yes or no)
10. AutoShut Tank – Auto shutdown on tank full (yes or no)

11. FWF Duration – FWF duration time (HH:mm:ss)
12. FWF Interval – FWF interval time (HH:mm:ss)
13. AutoStart Tank – Autostart on tank empty (yes or no)
14. Salinity Level – Salinity error level (ppm)
15. Min Pressure – minimum pressure (Bar or PSI)
16. Max Pressure – Maximum pressure (Bar or PSI)
17. Sol. Valve Time – Solenoid valve time (seconds)

Fresh Water Flush button

This button initiates the Fresh Water Flush (FWF) cycle. The cycle can be interrupted by pressing this button again to stop operation. Note that this button starts the FWF cycle, regardless of whether or not you are browsing a menu.

Booster Pump button

Start the booster pump. Press the Start/Stop button to stop operation. Note that this button starts the booster pump, regardless of whether or not you are browsing a menu.

Shutting Down the Seafari Quest System

The freshwater flush pump is equipped with a pressure switch that will cycle the pump on and off. If the pump's outlet pressure is below 45 PSI, the pump will operate; when the pump's outlet pressure is above 45 PSI, the pump will stop. The freshwater flush pump will cycle on and off during the freshwater flush cycle. This is normal and to be expected.

1. Prior to stopping the system, determine if the system will be stored for a period of time or if it will be operated again soon. Failure to properly flush and or store the system will lead to premature fouling or drying out of the RO Membrane Element, which is not covered by the Horizon Reverse Osmosis Warranty and is the liability of the operator of the system. the system will not be operated within the next month or longer, perform a long-term storage operation.
 - a) If the system will be exposed to freezing temperatures, you must follow winterizing procedures. Freezing temperatures will cause extensive damage if the system is not properly protected.
 - b) If the system will be operated within the next two weeks, no action is necessary besides winterization for freezing temperatures.
 - c) If the system will not be operated within the next two weeks, perform a freshwater flush. If the Horizon Reverse Osmosis Automatic Freshwater Flush is installed, ensure that the potable water storage tank has fresh potable water for the freshwater flush to utilize in rinsing the system. If the system does not include an automatic freshwater flush, perform a manual freshwater flush of the system.
 - d) If the system will not be operated within the next month or longer, perform a long-term storage operation.
2. Stop the system by pressing the "START/STOP" button once. After a 90 minute delay period, the freshwater flush automatic cycle will begin, as indicated on the LCD Screen. The time delay is to allow the ETD to dissipate its pressure.

The freshwater flush pump is equipped with a pressure switch that will cycle the pump on and off. If the pump's outlet pressure is below 45 PSI, the pump will operate; when the pump's outlet pressure is above 45 PSI, the pump will stop. The freshwater flush pump will cycle on and off during the freshwater flush cycle. This is normal and to be expected.

The freshwater flush cycle will last for approximately 10 minutes. The 10-minute cycle is adjustable. Every 7 days, the freshwater flush rinse cycle will repeat automatically.

If the "START/STOP" button is pressed twice, the automatic freshwater flush cycle will be cancelled.



3. Close the Inlet Sea Cock Valve. This is a safeguard for vessel installations.
4. If the freshwater flush is installed and activated, do not interrupt power. If the freshwater flush is not installed or is not activated, turn off the electrical power source (circuit breaker) to the system. This eliminates the chance of inadvertently starting the system. If the power source has been turned off, the freshwater flush will not cycle every 7 days.

Chapter 9





System Storage and Cleaning

Membrane Element Handling and System Storage Warnings

Freezing Temperatures

-  **Caution:** The System must be protected from freezing if it will be exposed to temperatures below 32°F (0°C). Freezing temperatures will cause extensive damage to the System as the water expands during the freezing process. Resulting damage to the System caused by freezing temperatures is the liability of the Operator.
-  **Caution:** DO NOT subject the System to temperatures below 32°F (0°C), unless the System has been rinsed with a solution of Product Water with 20% food-grade Glycerin (Propylene-Glycol).

RO Membrane Element Handling

-  **Caution:** Never store the RO Membrane Element or Membrane/Vessel Assembly in direct sunlight. Never expose the RO Membrane Element or Membrane/Vessel Assembly to storage temperatures above 120°F (50°C) or below 32°F (0°C). High temperatures may cause irreversible damage and up to 40% production loss in the RO Membrane Element. Freezing temperatures cause mechanical System damage, as well as irreversible damage to the RO Membrane Element.
-  **Caution:** The RO Membrane Element must remain wet at all times. Never allow the RO Membrane Element to dry out, as drying out may cause up to 40% production loss, as well as irreversible damage. Some, but not all, production may be restored by saturating the RO Membrane Element in Product Water for several days, and then operating the System by feeding Product Water into the System for a continuous 48-hour period.
-  **Caution:** Never expose the RO Membrane Element to chemicals other than those supplied by Horizon Reverse Osmosis. Use caution when operating the system in harbors that may be polluted with chemicals, oil or fuel, as these chemicals may damage the RO Membrane Element beyond repair.
-  **Caution:** Protect the RO Membrane Element from biological fouling, as it may cause significant production loss. Some, but not all, production may be restored after cleaning. The System must be protected from biological fouling if it will not be operated over a period of two (2) weeks or more.
-  **Important:** Third-party chemicals will destroy the RO Membrane Element! Only use Horizon Reverse Osmosis-supplied chemicals. Never use third-party chemicals, as they are incompatible with various System materials and will dissolve the co-polymer parts. Damage to the System or its components as a result of using third-party chemicals is not covered by the Horizon Reverse Osmosis Corporation Warranty.

Fresh Water Flush

There must be sufficient Fresh Water in the Potable Water Storage Tank. In order to provide the required water flow to the System during the Fresh Water Flush cycle, the ship's fresh-water pressure system must deliver a

minimum of 1 U.S. Gallons (3.8 Liters) per minute at minimum 25 PSI and maximum 60 PSI (minimum 172 kPa and maximum 414 kPa).

- If the Minimum of 1 U.S. Gallons (3.8 Liters) per minute at minimum 25 PSI (minimum 172 kPa) is not achieved, then the System may not fully flush the System with enough fresh water to displace the Feed Water (i.e., sea water).
- If the Maximum 60 PSI (maximum 414 kPa) is exceeded, then the System will shut down and revert to a fault mode due to excess pressure. In this event, the Owner or Installer must install a Pressure Reduction Valve from the ship's Pressurized Fresh Water Line prior to the inlet of the System Fresh Water Flush Charcoal Filter Inlet.

System Storage

If the System is not equipped with the Automatic Fresh Water Flush option or it will not be operated for an extended period of time (i.e., three months or longer), then you must perform a manual fresh water flush.

Fresh Water Flush

Automated Fresh Water Flush

If the Automated Freshwater Flush (FWF) Accessory is installed, after a 90-minute delay, the Seafari Quest is flushed with freshwater automatically each time the system is stopped after operation. The Seafari Quest may also be flushed with freshwater simply by pressing the FWF switch at the touch pad. Refer to the two diagrams in this chapter, which illustrate the water flow when the Seafari Quest is performing an Automated Freshwater Flush, if the included Freshwater Flush Accessory is installed.

Manual Fresh Water Flush

If the Automated Freshwater Flush Accessory is not installed, or if a manual freshwater flush is preferred, when the instructions within this chapter state “configure for once-through rinse” to rinse the system with freshwater for short-term non-use in non-freezing temperatures, proceed as follows.

1. Configure the suction line for a once-through process.
 - a) Close the Sea Cock Valve.
 - b) If the Optional Rinse/Clean Inlet Valve is not installed, disconnect the hose from the outlet line of the Sea Strainer, and place it in the Rinse/Clean Solution Container or bucket.
 - c) If the Optional Rinse/Clean Inlet Valve is installed, position it to draw water from the Rinse/Clean Container.
2. Configure the brine discharge line for a once-through process.
 - a) Connect the brine discharge line from the system to the thru-hull overboard discharge fitting. This is the normal connection for normal operation.
 - b) If the system is equipped with an Optional Discharge Rinse/Clean Outlet Valve, position this valve to discharge through the Brine Discharge Connector. This is the normal connection for normal operation.

Once-Through Depressurized Rinse

When the instructions within this chapter state “configure for once-through depressurized rinse” used for once-through flushing of storage chemical, winterizing chemical or rinse between RO Membrane cleaning, proceed as follows. Refer to the two diagrams illustrated in this chapter.

1. In order to relieve pressure during the once-through winterizing rinse process, the Pressure Relief Tube Kit must be installed.
 - a) Disconnect only one end of the High-Pressure Hose MVA Outlet/Energy Transfer Device Return either from the RO Membrane/Vessel Assembly Outlet (brine discharge end) or from the ETD (whichever is easier to access).
 - b) Connect the Product Relief Tube Kit to the loose end of the High-Pressure Hose and to the exposed fitting on the RO Membrane/Vessel Assembly Outlet or the ETD fitting (whichever fitting the High-Pressure Hose was disconnected from).
 - c) Route the ³ -inch O.D. Tube from the Pressure Relief Tube Kit into the Rinse/Clean Solution Container or bucket.

2. Configure the suction line for a once-through process.
 - a) Close the Sea Cock Valve.
 - b) Disconnect the outlet line from the Sea Strainer and place it in the Rinse/Clean Solution Container.
 - c) If the System is equipped with an Optional Inlet Rinse/Clean Valve between the Sea Strainer and Booster Pump, then position this valve to draw from the Rinse/Clean Solution Container.
3. Configure the brine discharge line for a once-through process.
 - a) Connect the brine discharge line from the system to the thru-hull overboard discharge fitting. This is the normal connection for normal operation.
 - b) If the System is equipped with an Optional Discharge Rinse/Clean Outlet Valve, position this valve to discharge through the Brine Discharge Connector. This is the normal connection for normal operation.

RO Membrane Element Cleaning Closed Loop

When the instructions within this chapter state “configure for RO Membrane Element Cleaning Closed Loop,” proceed as follows.

1. In order to relieve pressure during the closed loop process, the Product Relief Tube Kit must be installed.
 - a) Disconnect only one end of the High-Pressure Hose MVA Outlet/Energy Transfer Device Return either from the RO Membrane/Vessel Assembly Outlet (brine discharge end) or from the ETD (whichever is easier to access).
 - b) Connect the Product Relief Tube Kit to the loose end of the High-Pressure Hose and to the exposed fitting on the RO Membrane/Vessel Assembly Outlet or the ETD (whichever fitting the High-Pressure Hose was disconnected from).
 - c) Route the $\frac{3}{4}$ -inch O.D. Tube from the Pressure Relief Tube Kit into the Rinse/Clean Solution Container or bucket.
2. Configure the suction line for a closed loop process.
 - a) Close the Sea Cock Valve.
 - b) Disconnect the outlet line from the Sea Strainer and place it in the Rinse/Clean Solution Container.
 - c) If the system is equipped with an Optional Inlet Rinse/Clean Valve between the Sea Strainer and Booster Pump, then position this valve to draw from the Rinse/Clean Solution Container.
3. Configure the brine discharge line for a closed loop process.
 - a) Disconnect the brine discharge line from the thru-hull overboard discharge fitting and place it in the Rinse/Clean Solution Container.
 - b) If the system is equipped with an Optional Discharge Clean/Rinse 3-way Ball Valve, position this valve to return to the Rinse/Clean Solution Container.

Short-Term Shutdown

A short-term shutdown is defined as a period of time in which the system is not utilized for up to four weeks. An effective short-term protection for the system and RO Membrane Element is a freshwater rinse of the entire system with freshwater (product water from the system). This prolongs the system life by minimizing electrolysis and retarding biological growth.

 **Important:** If the system is equipped with an automatic freshwater flush, then it is not necessary to read this chapter. The Automated Freshwater Flush rinses the system every 7 days automatically. However, see “Winterizing and Freezing” note below.

 **Important:** If the system is exposed to freezing temperatures, perform a manual freshwater rinse as described below, and follow the included winterizing instructions.

Manual Fresh Water Rinse Procedure

Follow the directions below if the system is not equipped with an Automated Freshwater Flush System or if the system will be subjected to freezing temperatures during non-use. This procedure displaces the system feed water with fresh water and allows a short-term shutdown for up to four weeks. Five gallons (19 liters) of fresh product,

or potable water, is required for the freshwater rinse. These instructions also explain how to winterize the system. One gallon (3.8 liters) of food-grade propylene glycol will be required to winterize the system.

1. Configure the system for a **“Once-Through Rinse.”**
2. Clean the Sea Strainer Mesh Screen.
3. Clean the Plankton Filter Element.
4. Clean (hose off) or replace the 25- and 5-micron prefilter elements with new 25- and 5-micron Horizon Reverse Osmosis prefiltration elements.
5. Fill the Rinse/Clean Solution Container or a 5-gallon container with clean, fresh water.
6. Press the “START/STOP” switch. The freshwater rinses the system and discharges out through the thru-hull discharge fitting.
7. Just prior to depleting the rinse water from the Rinse/Clean Solution Container, stop the system by pressing the “START/STOP” switch.
8. If the system will NOT be exposed to freezing temperatures, reconfigure the suction line for normal operation. If the system will be exposed to freezing temperatures during non-use, skip this step and go to step 9 below.
 - a) Leave the Sea Cock Valve closed.
 - b) Reconnect the Sea Strainer outlet line to the outlet of the Sea Strainer, or reposition the Inlet Clean Rinse Valve to the normal operating position.

IN NON-FREEZING TEMPERATURES THE SYSTEM MAY NOW BE LEFT UNATTENDED FOR SEVERAL WEEKS. A GUIDE WOULD BE 4 WEEKS IN WARM CLIMATES AND 8 WEEKS IN COLD CLIMATES. HOWEVER, IF THE SYSTEM WILL BE EXPOSED TO FREEZING TEMPERATURES, CONTINUE WITH THE FOLLOWING PROCEDURES:

9. If the system will be exposed to freezing temperatures during non-use of the system, configure the system for a “Once-Through Depressurized Rinse” using the Product Relief Tube Kit
10. Again, fill the Rinse/Clean Solution Container or a 5-gallon bucket with 4 gallons (15 liters) of clean, freshwater. Add 20% (1 gallon/3.8 liters) food-grade propylene glycol to the storage chemical solution. This prevents the water in the system from freezing.
11. Press the “START/STOP” switch. The winterizing solution rinses the system and discharges out the waste.
12. Just prior to depleting the winterizing solution from the Rinse/Clean Solution Container, stop the system by pressing the “START/STOP” switch twice (2 times) in order to stop the system as well as deactivate the freshwater flush cycle. Ensure that the “freshwater flush” lamp is NOT illuminated.
13. Reconfigure the system for normal operation:
 - a) Leave the Sea Cock Valve closed.
 - b) Reconnect the Sea Strainer outlet line to the outlet of the Sea Strainer or reposition the Inlet Clean Rinse Valve to the normal operating position.
 - c) Remove the Product Relief Tube Kit.
 - d) Reconnect the High-Pressure Hose.
14. The Sea Strainer and post-filtration chapter have not received winterizing solution in this process. The water must be drained from the respective components.
 - a) Remove the Sea Strainer bowl from the Sea Strainer and drain the feed water from it. Replace the Sea Strainer bowl back onto the Sea Strainer.
 - b) Remove the charcoal filter bowl from the charcoal filter and drain the product water from it. Replace the charcoal filter bowl back onto the charcoal filter.
 - c) Remove the pH neutralizer filter bowl from the pH neutralizer filter and drain the product water from it. Replace the pH neutralizer bowl back onto the pH neutralizer filter.
 - d) Disconnect the top and bottom tube fittings from the ultraviolet sterilizer and drain the product water from the UV sterilizer chamber. Reconnect the top and bottom tube fittings back onto the UV sterilizer.
 - e) Disconnect the freshwater line from the potable water storage tank to the freshwater flush pump or if a valve is installed in this line close it to isolate the potable water line from the freshwater flush pump.
 - f) Remove the Fresh Water Flush Charcoal Filter bowl and drain it. Replace the Fresh Water Flush Charcoal Filter bowl back onto the Fresh Water Flush Charcoal Filter.

IN FREEZING TEMPERATURES THE SYSTEM MAY NOW BE LEFT UNATTENDED DURING THE FREEZING TEMPERATURE SEASON. AFTER THE SEASON, THE SYSTEM SHOULD BE RINSED WITH STORAGE CHEMICAL IF IT WILL NOT BE OPERATED.

Long-Term Shutdown

A long-term or prolonged shutdown is a period in which the system is not used for longer than 3 to 4 months, depending on conditions. For this interval, the system should first be rinsed with freshwater, then stored with System and Membrane Element Storage Chemical (SRC SC). This chemical inhibits bacterial growth while maintaining the high flux and salt rejection of the RO Membrane Element. The long-term shutdown procedure requires 10 gallons (38 liters) of potable water. Follow the directions listed below.





 **Important:** If the system will be exposed to freezing temperatures during non-use, have ready (1 gallon / 3.8 liters) food-grade glycerin (propylene glycol), and follow instructions to add it to the storage chemical solution. This prevents the water in the system from freezing.

1. Configure the system for a “Once-Through Depressurized Rinse” using the Product Relief Tube Kit.
2. Close the Inlet Sea Cock Valve.
3. Clean the Sea Strainer Mesh Screen.
4. Clean the Plankton Filter Element.
5. Replace the prefiltration cartridges with new 25- and 5-micron Sea Recovery prefiltration elements.
6. Fill the Rinse/Clean Solution Container with non-chlorinated product water.
7. Start the system. The rinse water rinses the entire system and discharge to waste.
8. Just prior to depleting the rinse water from the Rinse/Clean Solution Container, stop the system by pressing the “START/STOP” switch twice to stop the system and also to abort the freshwater flush cycle.
9. Once again, fill the Rinse/Clean Solution Container with non-chlorinated product water.
10. Add ONLY 4 ounces (1/6th of the container) of SRC SC storage chemical to the water in the Rinse/Clean Solution Container.
11. Mix and thoroughly dissolve the solution in the Rinse/Clean Solution Container.
12. If the system will be exposed to freezing temperatures, add 1-gallon (4 liters) food-grade glycerin (propylene glycol) to the storage solution mixture. This prevents the system from damage in freezing temperatures.
13. Operate the system by pressing the “START/STOP” switch. The storage chemical solution flows from the container, through the system, and out the brine discharge thru-hull fitting.
14. Discard any remaining winterizing solution in a safe, environmentally friendly and legal manner.
15. Reconfigure the system for normal operation:
 - a) Leave the Sea Cock Valve closed.
 - b) Reconnect the Sea Strainer outlet line to the outlet of the Sea Strainer or reposition the Inlet Clean Rinse Valve to the normal operating position.
 - c) Remove the Product Relief Tube Kit.
 - d) Reconnect the High-Pressure Hose.
16. The Sea Strainer and post-filtration chapter have not received storage and winterizing solution in this process. The water must be drained from the respective components.
 - a) Remove the Sea Strainer bowl from the Sea Strainer and drain the feed water from it. Replace the Sea Strainer bowl back onto the Sea Strainer.
 - b) Remove the charcoal filter bowl from the charcoal filter, clean the inside of the bowl and replace the element with a new Horizon Reverse Osmosis charcoal filter element.
 - c) Remove the pH neutralizer filter bowl from the pH neutralizer filter, drain the product water from it and clean the inside of the bowl. Replace the pH neutralizer bowl back onto the pH neutralizer filter.
 - d) Disconnect the top and bottom tube fittings from the ultraviolet sterilizer and drain the product water from the UV sterilizer chamber. Reconnect the top and bottom tube fittings back onto the UV sterilizer.
 - e) Disconnect the freshwater line from the potable water storage tank to the freshwater flush pump or, if a valve is installed in this line, close it to isolate the potable water line from the freshwater flush pump.

- f) Remove the freshwater flush charcoal filter bowl; drain and clean the inside of the bowl. Replace the freshwater flush charcoal filter element with a new Horizon Reverse Osmosis freshwater flush charcoal filter element, and replace the bowl with new element back onto the housing.

The system may now be left unattended for up to 3 to 6 months. With ideal conditions, including a relatively new RO Membrane Element, a clean system prior to storage, cool temperatures and no leakage of storage chemical within the system, it provides protection for up to 6 months. Adverse conditions may provide less protection. Evaluate these factors before determining the proper interval between repeated rinsing and storage periods.

RO Membrane Element Cleaning Procedures

-  **Important:** Do not arbitrarily clean the RO Membrane in a new system. If a new system experiences low production or high salinity, then the system should be operated for up to 48 hours continuously to clear and saturate the RO Membrane Element product water channel. If a new system still experiences low production and or high salinity after 48 hours of continual operation, then contact the factory.
-  **Important:** The membrane element requires cleaning from time to time. Biological growth and salt accumulation eventually make replacement necessary. The frequency of required cleaning depends on the amount of production loss and salt-rejection loss resulting from normal use and exposure to feed water. In order to properly assess performance changes, it is important to maintain daily log readings for comparison.
-  **Important:** During performance comparisons, feed water temp, feed water salinity and system operating pressure must be taken into consideration and compensated for. After compensations, a 10% decline in productivity (GPH Flow) and/or a 10% increase in salt passage indicate that the RO Membrane Element may require cleaning.
-  **Important:** If the production rate has dropped dramatically since the last time the system was used, this may be due to drying out of the RO Membrane Element and/or fouling during storage. If the system has not been used for several months and the production rate has dropped dramatically since the last time used, try operating the system for 48 or more continuous hours to saturate the product water channel within the RO Membrane Element.
-  **Important:** A dramatic increase in product water production from one day to the next may be the result of a mechanical failure such as a broken O-ring or damaged RO Membrane Element.

RO Membrane Element Cleaning Water and Chemical Requirements

1. The Horizon Reverse Osmosis cleaning compounds are designed to clean in a closed loop configuration moderate fouling from the RO Membrane Element. If the RO Membrane Element is excessively fouled and in-field cleaning is not successful, the RO Membrane Element may be returned to Horizon Reverse Osmosis or to one of Horizon Reverse Osmosis's many service dealers for professional chemical cleaning. If your membrane requires professional cleaning, please contact Horizon Reverse Osmosis for a return authorization number, price quotation and return instructions. Note: Very heavily fouled RO Membrane Elements may be more cost-effective to replace rather than clean as the cleaning process will take several hours of labor, chemical cost and packaging and shipping charges to and from the factory.
2. **SRC MCC-1**, Membrane Cleaning Compound "No. 1" is an alkaline cleaner designed to clean biological fouling and slight oil fouling from the RO Membrane Element. Biological fouling is usually the first cause of the RO Membrane Element fouling. The system is constantly exposed to seawater and biological growth. If exposed to seawater and left to sit, the RO Membrane Element becomes fouled even with no actual system use. This fouling is minimized with freshwater rinsing whenever the system is not in use.
3. **SRC MCC-2**, Membrane Cleaning Compound "No. 2" is an acid cleaner designed to clean calcium carbonate and other mineral deposits from the RO Membrane Element. Mineral fouling is a slow process that takes place during use of the system. Therefore, if the system has relatively few hours of use yet shows signs of RO Membrane Element fouling, then that fouling is likely biological. If the system has several thousand hours of use, then there may be some mineral fouling combined with biological fouling.
4. **SRC MCC-3**, Membrane Cleaning Compound "No. 3" is used for iron fouling. It is not included in the SRC Membrane Cleaning Chemical Kit. If the system's RO Membrane Element is fouled with rust from iron piping,

then SRC CC-3 may be used for effective removal of light or moderate rust fouling. Heavily rust-fouled RO membranes may not be recoverable as rust not only fouls the membrane element but also damages the membrane surface.

-  **Caution:** Never expose the RO Membrane Element to chemicals other than those supplied by Horizon Reverse Osmosis. Use caution when operating the system in harbors that may be polluted with chemicals, oil or fuel, as these chemicals may damage the RO Membrane Element beyond repair.

RO Membrane Element Cleaning Instructions

Table 4: Product Water Required, in U.S. Gallons, for Cleaning of the RO Membrane Element

Chemical	Rinse water required	Cleaning water required	Second rinse water required	Final rinse water required	Total water required
CC-1	5	5	5	5	20
CC-2	5	5	5	5	20
CC-3	5	5	5	5	20

1. Configure the System for a **“Once-Through Depressurized Rinse”** using the Product Relief Tube Kit as illustrated in this chapter.
2. Close the Inlet Sea Cock Valve.
3. Clean the Sea Strainer Mesh Screen.
4. Clean the Plankton Filter Element.
5. Replace the pre-filtration cartridges with new 25- and 5-micron Sea Recovery pre-filtration elements.
6. Fill the Rinse/Clean Solution Container with non-chlorinated product water.
7. Start the system. The rinse water rinses the entire system and discharge to waste.
8. Just prior to depleting the rinse water from the Rinse/Clean Solution Container, stop the system by pressing the **“START/STOP”** switch twice to stop the system and also to abort the freshwater flush cycle.
9. Once again, fill the Rinse/Clean Solution Container with non-chlorinated product water.
10. Add to the product water in the Rinse/Clean Solution Container one container (plastic bottle 1.5 lbs.) of Horizon Reverse Osmosis Membrane Element Cleaning Compound HRO MCC 1, HRO MCC 2, or HRO MCC 3 (only one chemical as appropriate for the type of cleaning desired). **DO NOT ADD ANY OTHER CHEMICAL. DO NOT MIX MORE THAN ONE CHEMICAL TO THE WATER.**
11. Mix and thoroughly dissolve the solution in the Rinse/Clean Solution Container.
12. Configure the System for a **“RO Membrane Element Cleaning Closed Loop.”**
13. Disconnect the brine discharge line from the brine discharge tee and place it into the storage/cleaning container.
14. If the Clean/Rinse Outlet Valve is installed, position it to return to the storage/cleaning container.
15. Operate the system by pressing the **“START/STOP”** switch. The membrane cleaning solution flows from the container through the system and back into the container in a closed loop configuration.
16. After approximately one hour of circulation, stop the system by pressing the **“START/STOP”** switch twice, which will also disable the freshwater flush cycle.
17. Discard the cleaning chemical solution in a safe, environmentally friendly and legal manner.
18. To closed loop rinse the cleaning chemical from the system, again fill the Rinse/Clean Solution Container or bucket with 5 gallons of non-chlorinated product water.
19. Operate the system by pressing the **“START/STOP”** switch. The rinse water flows from the container through the system and back into the container in a closed loop configuration.
20. After approximately 15 minutes of circulation, stop the system by pressing the **“START/STOP”** switch twice, which will also disable the freshwater flush cycle.
21. Discard the rinse water in a safe, environmentally friendly and legal manner.
22. Perform a final rinse. Reconfigure the system for a **“ONCE-THROUGH DEPRESSURIZED RINSE”**.
23. Reconnect the brine discharge line to the brine discharge tee.

-
24. If the Clean/Rinse Outlet Valve is installed, position it to discharge out toward the brine discharge connector.
 25. One final time, fill the Rinse/Clean Solution Container with non-chlorinated product water.
 26. Start the system. The rinse water rinses the entire system and discharge to waste.
 27. Just prior to depleting the rinse water from the Rinse/Clean Solution Container, stop the system by pressing the "START/STOP" switch once to initiate the Automated Freshwater Flush Cycle every 7 days. Press the "START/STOP" switch twice to abort the Automated Freshwater Flush Cycle.
 28. Reconfigure the system for normal operation:
 - a) Reconnect the Sea Strainer outlet line or reposition the Inlet Rinse/Clean Valve to normal operation position.
 - b) Remove the Product Relief Tube Kit.
 - c) Reconnect the High-Pressure Hose.

The system may now be operated or left unattended for up to 4 to 8 weeks, refer to the short-term storage procedures. If the system will be stored without use for longer than 8 weeks, refer to the long-term storage procedures to winterize the system. If the system will be stored in freezing temperatures refer to short-term storage procedures or long-term storage procedures, as appropriate, to winterize the system.

Closed Loop Configuration

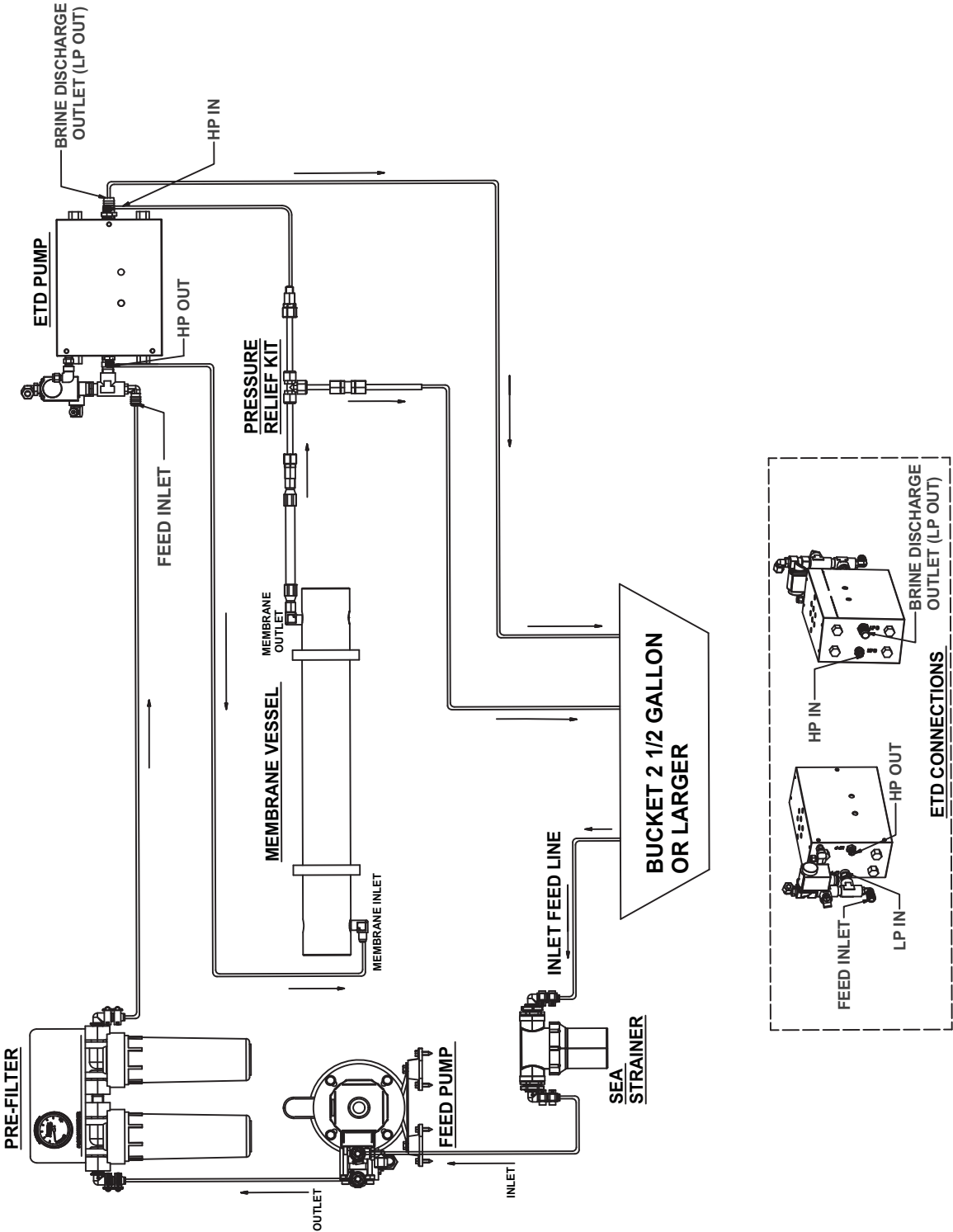

Chapter 10

Troubleshooting

Error ID 1: High Pressure Fault

System produces expected product water flow with normal operating pressure after compensating for Feed Water Salinity and Temperature; however, the Product Water salinity is above 100ppm for more than 10 consecutive seconds.

1. We recommend using a portable TDS meter to determine if the problem is with the RO Membrane Element or with the Salinity Probe and Electronic monitoring system.
2. A damaged or worn Product Water O-ring at one of the End Plugs within the High Pressure Vessel is allowing Feed Water to mix with Product Water, which would typically result in higher than normal Product Water Flow. However, a small nick in the O-ring may allow enough Feed Water to mix with the Product Water to cause the condition without resulting in a noticeable increase in Product Water Flow.
3. A crack in one of the End Plugs within the High Pressure Vessel is allowing Feed Water to mix with Product Water, which would typically result in higher than normal Product Water Flow. However, a small crack may allow enough Feed Water to mix with the Product Water to cause the condition without resulting in a noticeable increase in Product Water Flow.
4. RO Membrane Element is fouled due to normal use and requires cleaning.
5. Salinity Probe has debris on the probe causing the system to read poor water quality. Clean the Salinity Probe with a toothbrush.

Error ID 2: High Pressure Fault

If the High Pressure Sensor increases beyond 950 PSI and the System shuts down, press the "Start/Stop" button. A high pressure fault can be caused by:

- Low Temperature Feed Water
- High Salinity Feed Water
- Fouled RO Membrane Element
- Blockage in the Brine Discharge Line
- Blockage in the Product Water Line

Error ID 3: Low Pressure Fault

A low pressure fault can occur when the following conditions occur:

- The value at the Low Pressure Sensor is below 4 PSI for more than 20 seconds
- The Low Pressure Sensor is disconnected or malfunctioning
- The value at the High Pressure sensor is below 4 PSI for more than 20 seconds
- The High Pressure Sensor is disconnected or malfunctioning

To troubleshoot, check for the following:

- Cock Valve must be fully open
- Air suction leaks at all components and fittings prior to the Feed Pump
- Whether or not the Sea Strainer Mesh Screen is clean (no manufacturing or installation debris) and if air suction leaks are present
- Whether or not the Pre-filter Element is clean (no manufacturing or installation debris)
- Whether or not the Plankton Filter Element is clean (no manufacturing or installation debris)

- No kinks, blockages or air suction leaks in the inlet line
- The Feed Pump is operational and delivering flow and pressure
- Whether or not the Inlet Thru-Hull Fitting is clean (no manufacturing or installation debris) and if air suction leaks are present
- Caulking compound within the opening
- Shipping cover or tape below the hull in the water
- Casting slag on the “fingers” below the hull in the water or within the orifice
- Plastic bag or other debris in the water below the hull in the water

Error ID 4: Low Voltage Fault

Check system voltage inside the Control Panel. The system must receive adequate voltage at start up and during operation for normal operation. DC systems will shut down by design when the voltage falls below:

- 12 VDC Systems: 10.5 VDC
- 24 VDC Systems: 21.5 VDC

3-Way Product Water Diversion Valve Abnormalities

1. The Water Quality is less than 1000ppm; however, the Diversion Valve does not divert potable water to the post filtration section and onto the boat’s potable water storage tank.

1. The Diversion Valve is not energizing, and the valve’s coil is cool to the touch after several minutes of operation with the Water Quality is less than 1000ppm.
 - The 3-way Product Water Diversion Valve may have a defective solenoid coil.
 - There may be a loose wire connection at the Control Printed Circuit Board or the solenoid’s din connector.
 - The Control Printed Circuit Board may not be delivering 12 VDC to the solenoid.

2. The 3-way Diversion Valve is receiving 12 VDC when the Water Quality is less than 1000 ppm safe water. The valve’s solenoid coil is not defective, nor is it warm or hot to the touch; however the Diversion Valve does not divert potable water to the post filtration section and onto the boat’s potable water storage tank.

The Diversion Valve internal ports may have been moved by over tightening of the black tube fittings causing blockage internally and require adjustment. Remove Diversion Valve from the system and adjust ports.

High-Pressure or Low-Pressure Abnormalities Due to Mismatch of Components

The Seafari Quest System is designed to recover a fixed percentage of the feed water as product water. The System self-adjusts the operating pressure in order to maintain a constant and set product water flow. Therefore, the System will never experience greater than or less than normal product water flow, unless there is a failure or abnormality.

Three components must be properly matched in order to attain acceptable operating pressure limits and resulting product water production limits: the ETD, RO Membrane Element and the Feed Pump. Upon leaving Horizon Reverse Osmosis’ factory at the time of shipment, these components have been matched and tested together as a system.

If the initial Horizon Reverse Osmosis customer (distributor, dealer or boat builder) has mistakenly interchanged one or more of these components with other system components in their stock, this will cause a mismatch resulting in insufficient operating pressure, insufficient product water flow, excessive operating pressure or excessive product water flow. If one or more of these components has recently been replaced, it may have been replaced with the incorrect component.

If the system is new and being operated for the first time or if one or more of the above-mentioned components has recently been replaced, check to ensure that the three components are properly matched. Refer to the following two pages.

ETD: If the ETD has been improperly changed to a higher size code from “B-22” to “B-25,” product water flow will increase along with higher-than-normal operating pressure. The High-Pressure Sensor will eventually signal the system to shut down due to excess pressure at the membrane.

If the ETD has been improperly changed to a lower size code from “B-25” to “B-22,” product water flow will decrease along with lower-than-normal operating pressure and poor product water quality.

Feed PUMP: If the Feed Pump has been improperly changed to a higher size code (i.e., from 100 GPH to 140 GPH) product water flow will increase along with higher-than-normal operating pressure. The High-Pressure Sensor will eventually signal the system to shut down due to excess pressure at the membrane.

If the Feed Pump has been improperly changed to a lower size code (i.e., from 190 GPH to 125 GPH) product water flow will decrease along with lower-than-normal operating pressure and poor product water quality.

RO MEMBRANE ELEMENT: If the RO Membrane Element has been improperly changed to a HIGHER size code from “A” to “B” or “C” or from “B” to “C,” then product water flow will not change and the operating pressure will decrease resulting in poor product water quality.

If the RO Membrane Element has been improperly changed to a lower size code from “B” to “A” or from “C” to “B” or “A,” then product water flow will not change but the operating pressure will increase. The High-Pressure Sensor will eventually signal the system to shut down due to excess pressure at the membrane.

Product Water Abnormalities

- Insufficient Product Water Flow
- Excessive Product Water Flow
- Poor Quality Product Water

The production of the system (product water flow) and the quality of the product water (high quality indicates low salinity; low quality indicates high salinity) are dependent upon the proper amount of feed water flow and operating pressure at the RO Membrane Element. Product water flow or quality abnormalities can be the result of pressure abnormalities described on the previous pages, which are repeated below.

Production abnormalities can also be the result of worn seals, worn O-rings, cracks or damage at sealing surfaces, or a fouled RO Membrane Element.

Quality abnormalities can also be the result of worn seals, worn O-rings, cracks or damage at sealing surfaces, or a fouled RO Membrane Element, Feed Water Temperature, and/or feed water salinity.

Lower-Than-Normal Product Water Flow

A blockage in the suction line, resulting in a heavy vacuum reading at the Feed HP Inlet Pressure, will cause the Feed Pump to cavitate and lead to a reduction of feed water flow and Feed Pump outlet pressure. The Seafari Quest System is designed to recover a set percentage of the feed water as product water. Therefore, if the Feed Pump flow decreases due to cavitation, then the product water flow will decrease accordingly.

Likewise, a blockage in the prefiltration, resulting in an excessive pressure reading at the HP Inlet Pressure, will restrict the Feed Pump water flow and feed water pressure at the outlet of the prefilters. Again, the Seafari Quest System is designed to recover a set percentage of the feed water as product water. Therefore, if the Feed Pump flow decreases due to a blockage at the prefiltration, then the product water flow will decrease accordingly.

A decrease in product water flow can also be caused by a fouled RO Membrane Element. However, as the RO Membrane Element becomes fouled, the HP Inlet Pressure and Membrane Pressure will all register higher-than-normal pressure as the system self-adjusts to overcome the fouling. The High-Pressure Sensor will eventually signal the system to shut down due to excess pressure at the Membrane when pressure increases to 925 PSI.

Lower-than-normal feed water temperature causes the RO Membrane to require greater operating pressure in order to maintain the normal product water production. The Seafari Quest System self-adjusts by increasing the operating pressure to compensate for lower-than-normal feed water temperature.

A blockage in the product water line will cause lower-than-normal product water flow. The Seafari Quest System will attempt to self-adjust the operating pressure to overcome the drop in product water flow caused by a blockage in the product water line. The High-Pressure Sensor will eventually signal the system to shut down due to excess pressure at the Membrane when this pressure increases to 925 PSI.

Higher-Than-Normal Product Water Flow

Mismatching of system components can cause higher-than-normal product water flow accompanied by increased operating pressure. The High-Pressure Sensor will eventually signal the system to shut down due to excess pressure greater than 925 PSI at the Membrane.

A worn or broken product water O-ring at the end plug inside the high-pressure vessel will allow feed water to bypass into the product water to produce a greater-than-normal amount of product water. The resulting mixture of product water and feed water will be of low quality, or high in salinity. This will also appear as lower-than-normal operating pressure at the Membrane Pressure.

A crack in the end plug between the feed water port and product water port or a rough surface at the product water O-ring will also allow feed water to bypass into the product water causing the product water flow to increase. The resulting mixture of product water and feed water will be of low quality, or high in salinity. This will also appear as lower-than-normal operating pressure at the Membrane Pressure.

Higher-than-normal feed water temperature causes the RO membrane to require less operating pressure in order to maintain the normal product water production. The Seafari Quest System self-adjusts by decreasing the operating pressure to compensate for higher-than-normal feed water temperature. Product water quality will decrease, or increase in salinity, as the operating pressure is decreased to compensate for the higher-than-normal feed water temperature.

Low Product Water Quality (Increased Salt Content in the Product Water)

Mismatching of system components can cause lower-than-normal operating pressure resulting in low-quality product water. A worn or broken product water O-ring at the end plug inside the high-pressure vessel will allow feed water to bypass into the product water. The resulting mixture of product water and feed water will be of low quality, or high in salinity. This will also appear as lower-than-normal operating pressure at the Membrane Pressure.

A crack in the end plug between the feed water port and product water port or a rough surface at the product water O-ring will also allow feed water to bypass into the product water. The resulting mixture of product water and feed water will be of low quality, or high in salinity. This will also show up as lower-than-normal operating pressure at the Membrane Pressure.

Higher-than-normal feed water temperature causes the RO membrane to require less operating pressure in order to maintain the normal product water production. The Seafari Quest System self-adjusts by decreasing the operating pressure to compensate for higher-than-normal feed water temperature. Product water quality will decrease, or increase in salinity, as the operating pressure is decreased to compensate for the higher-than-normal feed water temperature.

A fouled RO Membrane Element will produce poor-quality product water since the RO Membrane Element allows a constant passage of dissolved solids, salt and other minerals. The water molecules passing through the RO Membrane Element dilute the constant amount of dissolved solids. Therefore, the greater the amount of water passage, the lower the concentration, or lower percentage, of dissolved solids. As the RO Membrane Element becomes fouled, less water passes through it to dilute the constant dissolved solids' passage. This results in poor-quality product water. The Seafari Quest System self-adjusts the operating pressure to overcome the fouling. Eventually the High-Pressure Sensor will signal the system to shut off due to excessive operating pressure above 925 PSI.

If there is a Sulfurous odor (rotten egg smell) in the product tank, check for the following:

1. Dirty Pre-Filtration Element.
 - Dirty Pre-Filtration Elements allow biological matter to decay. When this biological matter decomposes, sulfur gas is released as a byproduct.
 - Check and replace as necessary Pre-filtration and Post Filtration Elements.
2. Charcoal Filter Element requires replacement.
 - Change the Charcoal Filter Element every 3 months.
3. Product Tank is dirty or has biological growth in it.
 - Clean and Chlorinate product tank.

Chapter 11

Electrical Information

- ⊘ **Caution: ELECTRICAL SHOCK HAZARD.** A Volt/Ohm Meter will be necessary for some troubleshooting and subsequent corrective actions. The following procedures expose the technician to high voltage and electrical shock hazard. Only attempt this if you are a qualified electrician and surrounding conditions are safe.
- ⊘ **Caution:** Always allow slack in electrical cables. Allow the cable to enter or leave from the strain relief in a straight manner for several inches to ensure proper connection, to relieve stress to the cable and fitting, and to allow ease of detachment and reattachment for maintenance or replacement. If electrical cables are pulled tight causing them to bend at the strain relief they will pull out of the strain relief causing a dangerous electrical shock condition, the wire may break, and the strain relief will lose its watertight integrity.
- ⊘ **Caution:** Review the “Check Off Q.C. Sheet” that accompanied this Owner's Manual and the Invoice that accompanied this Seafari Quest System to ensure that it has been configured from Horizon Reverse Osmosis for the appropriate and proper DC Voltage.

Notes:

1. A 12 VDC System will NOT function from 24 VDC Power.
2. A 24 VDC System will NOT function from 12 VDC Power.

Remove the Front cover from the system controller to access the Main Terminal Strip and Printed Circuit Board. System configuration, optional Accessories present, and the specific model all are contributing factors to the amount of electrical connections required during installation. The following items are listed but may either not be present (Optional Accessory not ordered) or may already be connected. Track each electrical wire to ensure proper connection. (** = Optional Accessory)

Seafari Quest System Required Electrical Connections

- Feed Pump Electric Motor
- Low Pressure Sensor
- High Pressure Sensor
- Fresh Water Flush Pump Electric Motor
- 3-way Product Water Diversion Solenoid Valve
- *** UV Sterilizer
- *** Remote Controller
- Electrical Power to the System

Electrical Requirements

Direct Current (DC) Powered Systems:

During start up, the current of the Feed Water Pump DC Electric Motor draws high amperage for a fraction of a second after which the Electric Motor begins to rotate. After the Electric Motor achieves full RPM rotation, the current drops to a normal running load. This process takes less than 0.5 seconds.

Therefore, the battery bank power source must be fully charged and of sufficient amperage storage capacity to provide and maintain the full voltage (12 VDC or 24 VDC, as appropriate) at the instant of starting the Feed Water Pump Electric Motor. If the battery bank power is insufficient, the Seafari Quest electronic circuit may “drop out”

due to power loss before the Electric Motor begins to rotate. This is an installation problem (insufficient power supply), *not* an Seafari Quest problem. Low DC voltage to the Booster Pump electric motor can also be caused by insufficient diameter power cables connected from the battery bank, through the boat's circuit breaker, and onto the Seafari Quest controller.

Power Source Requirements:

Check line voltage and frequency to ensure that it matches the System nameplate. Grounding and circuit protection should be done in accordance with National Electrical Code. See connection diagram on nameplate of motor or refer to the diagrams within this manual.

Voltage	HZ (AC)	Min. HZ	Max. HZ	Min. Voltage	Max. Voltage
DC Systems					
12 VDC	N/A	N/A	N/A	11 VDC	15 VDC
24 VDC	N/A	N/A	N/A	22 VDC	30 VDC

Feed Pump Motor Electrical Specification

12 and 24 VDC	SQ 200 12V / 24V	SQ 400 12V / 24V	SQ 600 12V / 24V
Nominal Operating Amps	16 / 8	21 / 13	39 / 20
Maximum Motor Amps	28 / 13.4	28 / 13.4	39 / 19.5
Horse Power	.3	.3	.5
Recommended Circuit Breaker	30 / 15	45 / 20	65 / 30
Minimum Size Power Wire AWG	6 / 8	6 / 8	6 / 8
Minimum Size Power Wire mm2	13 / 8	13 / 8	13 / 8

Nominal Operating Amperage will increase if:

- The Feed Water Temperature is Lower than 77° Fahrenheit / 25° Celsius.
- The Feed Water Salinity is Greater than 35,000 PPM TDS (3.5% Total Dissolved Solids)
- The RO Membrane Element becomes fouled
- The RO Membrane Element is new and on the minus 15% side of the specifications

Nominal Operating Amperage will decrease if:

- The Feed Water Temperature is Higher than 77° Fahrenheit / 25° Celsius.
- The Feed Water Salinity is Less than 35,000 PPM TDS (3.5% Total Dissolved Solids)
- The RO Membrane Element is new and on the plus 15% side of the specifications

Wire Size Cross Reference American Wire Gauge (AWG) vs. Metric Wire Sizes

AWG	Diameter Inch	Square Inch (In ²)	Diameter Millimeters	Square Millimeters (mm ²)
0000	0.4600	0.1661	11.6840	107.1649
000	0.4096	0.1317	10.4038	84.9683
00	0.3648	0.1045	9.2659	67.3980
0	0.3249	0.0829	8.2525	53.4609
1	0.2893	0.0657	7.3482	42.3871
2	0.2576	0.0521	6.5430	33.6069
3	0.2294	0.0413	5.8268	26.6516

AWG	Diameter Inch	Square Inch (In²)	Diameter Millimeters	Square Millimeters (mm²)
4	0.2043	0.0328	5.1892	21.1385
6	0.1620	0.0206	4.1148	13.2913
8	0.1285	0.0130	3.2639	8.3626
10	0.1019	0.0082	2.5883	5.2588
12	0.0808	0.0051	2.0523	3.3064
14	0.0641	0.0032	1.6281	2.0809
16	0.0508	0.0020	1.2903	1.3070
18	0.0403	0.0013	1.0236	0.8225
20	0.0320	0.0008	0.8128	0.5186
22	0.0254	0.0005	0.6452	0.3267

American Wire Gauge			Metric Wire Gauge		Metric Wire
AWG	dia inch	sq. inch	dia mm	sq mm	Size mm²
0000	0.4600	0.1661	11.6840	107.1649	100
000	0.4096	0.1317	10.4038	84.9683	85
00	0.3648	0.1045	9.2659	67.3980	65
0	0.3249	0.0829	8.2525	53.4609	50
1	0.2893	0.0657	7.3482	42.3871	40
2	0.2576	0.0521	6.5430	33.6069	32
3	0.2294	0.0413	5.8268	26.6516	32
4	0.2043	0.0328	5.1892	21.1385	19
6	0.1620	0.0206	4.1148	13.2913	13
8	0.1285	0.0130	3.2639	8.3626	8
10	0.1019	0.0082	2.5883	5.2588	5
12	0.0808	0.0051	2.0523	3.3064	3
14	0.0641	0.0032	1.6281	2.0809	2
16	0.0508	0.0020	1.2903	1.3070	1
18	0.0403	0.0013	1.0236	0.8225	0.8
20	0.0320	0.0008	0.8128	0.5186	0.5
22	0.0254	0.0005	0.6452	0.3267	0.35

Chapter 12

Exploded Parts View

H011M SEAFARI QUEST MODULAR

ITEM NO.	QTY.	PART NUMBER	DESCRIPTION
1	1	B595100029	CONTROLLER 12V-SQC
2	1	H515111002	LP BACK PLATE ASSY SQM
3	1	3120225304	FRONT COVER, SEAFARI QUEST MODULAR
4	1	3120225303	PLATE, BACK.WALL MOUNT, SEAFARI QUEST
5	1	05180851CC	BRACKET, GAUGE, CBM, SS
6	1	10181510CC	GAUGE 0-300 CBM.NPT
7	1	0217090887	CONN .25 TUBE x .25 MT SS
8	1	0217120887	CONN .25 TUBE x 0.25 FT SS
9	1	0217010887	ELB90 .25 TUBE X .25 FPT SS
10	1	061100066000	WASHER, FLAT, OS, 1/2", SS
11	4	061161130016	SC PHIL OVAL #10-24 X 1 SS
12	4	061161630008	SC PHIL FLAT 10-24 X 1-2 SS

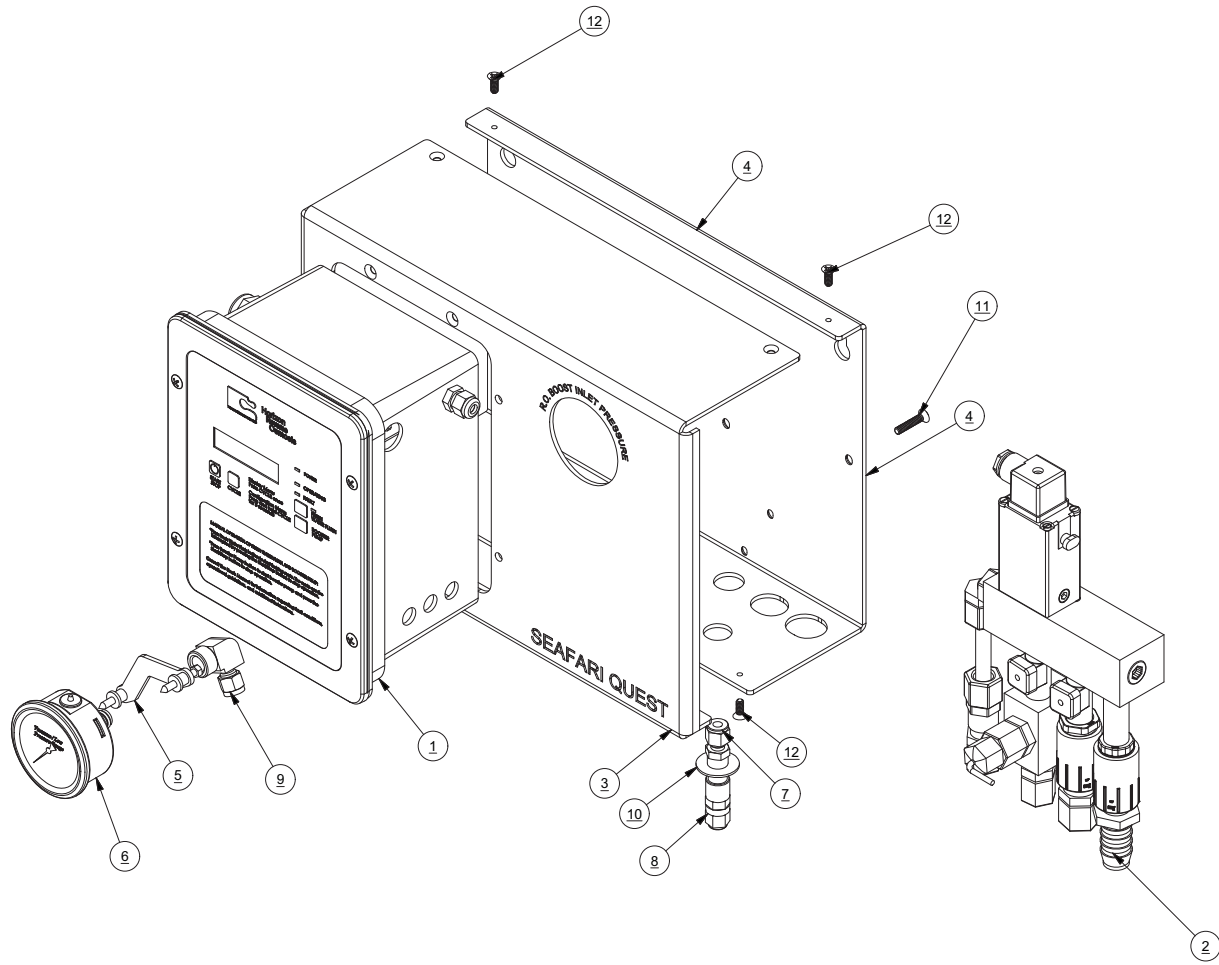

H010C SEAFARI QUEST COMPACT

ITEM NO.	QTY.	PART NUMBER	DESCRIPTION
1	1	B501290001	PLUMBING ASSEMBLY, UW DX
2	1	B107380004	PREFILTER ASSY UW-SE M4-600
3	1	B595100029	CONTROLLER 12V-SQC
4	1	B516010001	DIVERSION VALVE ASSEMBLY
5	1	B152380001	ETD PUMP ASSY, ULTRA WHISPER DX
6	1	B007380022	FEED PUMP ASSY UWSE 400-12 #15
7	1	B196120013	MEMBRANE VESSEL ASSY 400-2 GPD REAR MOUNTED
8	2	2020046401-2	BRACKET ,MEMBRANE MOUNTING, UWDX BJ
9	1	H31740052104	PLATE TOP HORIZONTAL 24 INCH
10	1	3120225302	FRAME FRONT COVER, SQC
11	2	20200404011	BRACKET L MOUNTING FEET-WHITE POWDER COAT
12	1	05180851CC	BRACKET,GAUGE,CBM,SS
13	1	10181523CC	GAUGE 0-70 CBM.NPT
14	1	0204121869	CONN .375 TUBE X .375 FPT PLASTIC
15	1	0217010887	ELB90 .25 TUBE X .25 FPT SS
16	2	0112021800	ELB90 .375 MNPT x .62 BARB NYLON
17	1	0204011869	ELB90 .375 TUBE X .375 FPT PLASTIC
18	1	0204022469	ELBOW,PP,1/2 ODx3/8 MT
19	8	061060045000	NUT HEX .25-20 W-INSERT SS
20	7	2132021600	RUBBER MOUNT GROMMET 1 1-4 OD Rev A_1.50
21	8	061142145012	BOLT HEX .25-20 X .75 SS
22	4	061142150016	BOLT HEX _31-18 X .75
23	7	061160631012	SC PHIL OVAL 10-32 X .75 SS
24	8	061080043000	WASHER FLAT .25 SS
25	4	061100049000	WASHER FLAT OS .312 SS
26	4	577001006A	VIBRATION ISOLATOR RUBER MOUNT

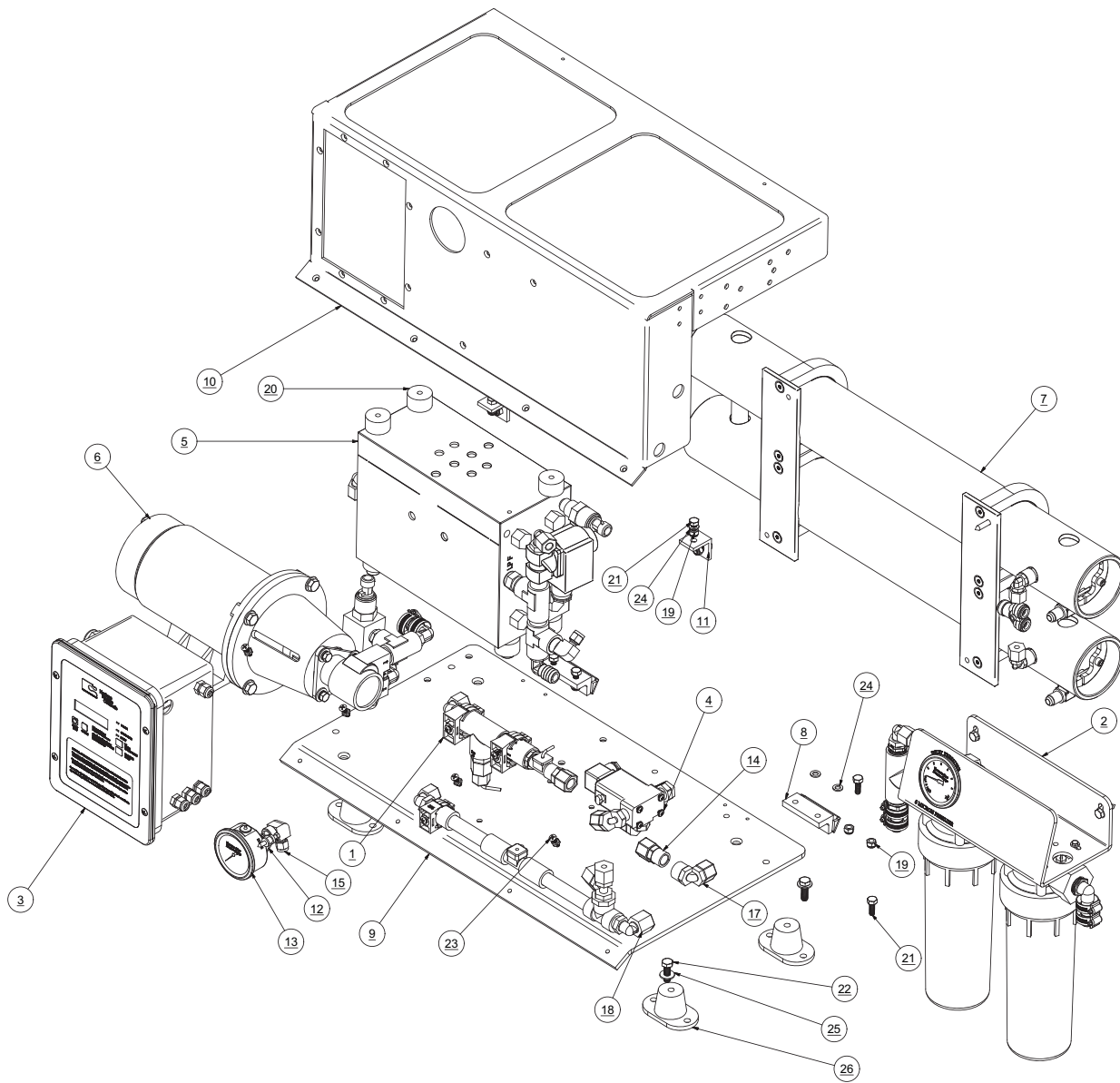

B006380002 SEA STRAINER UWDX 5IN

ITEM NO.	QTY.	PART NUMBER	DESCRIPTION
1	1	20200402102	BRACKET SINGLE FILTER
2	1	0819245201	ELEMENT,100 MICRON, 5"
3	1	0713020973	FILTER HOUSING-LID 0.50 X 5
4	2	0112022500	ELB90 .50 MNPT x .62 BARB NYLON
5	4	061172143016	SCREW,HEX A, .25x1.00,SS
6	4	05181434AA	HOSE CLAMP .75 SS
7	4	061170628016	SC PHIL PAN A #10 X 1 SS
8	4	065080028000	WASHER FLAT #10 NYLON
9	4	061080043000	WASHER,FLAT,1/4",SS

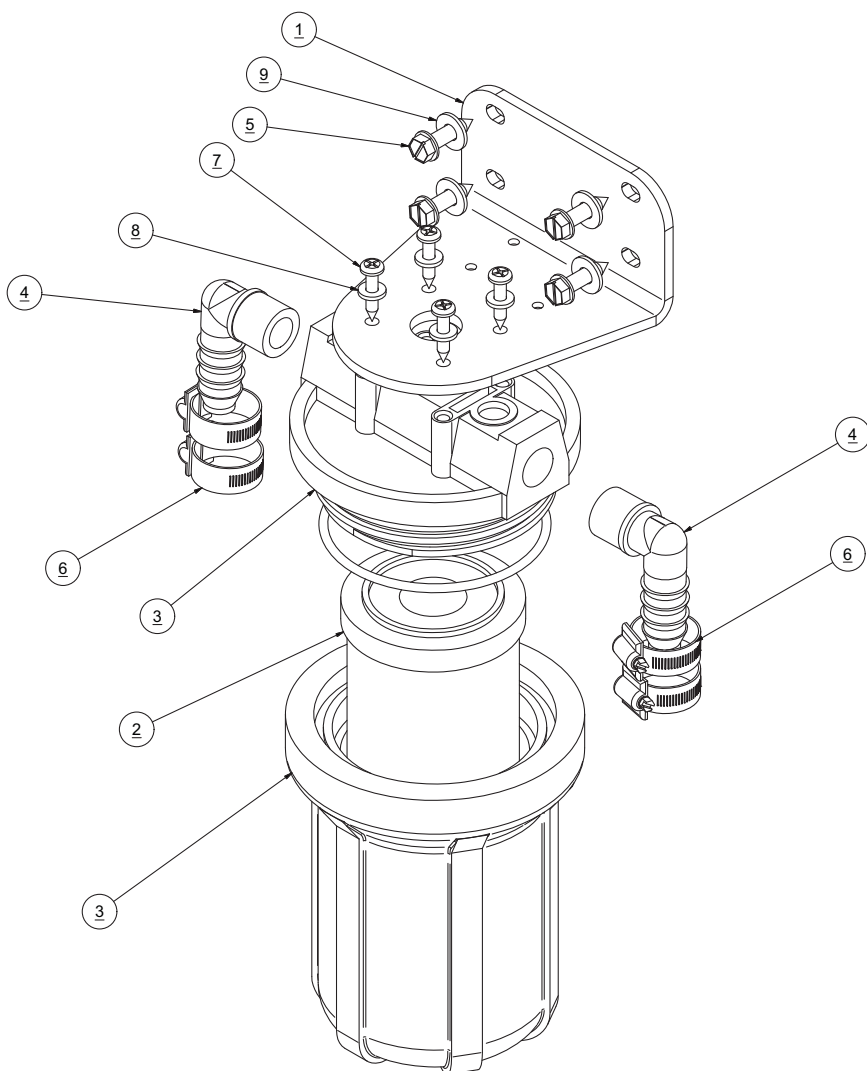

ETD-PUMP ASSY (13%)- COMPACT & MODULAR

PART NUMBER : B15230001 ETD-PUMP ASSY 13% MODULAR

PART NUMBER : B15230000 ETD-PUMP ASSY 13% COMPACT

ITEM NO.	QTY.	PART NUMBER	DESCRIPTION
1	1	12181301DS	ETD PUMP-NEW
2	1	2317100300	TRANSDUCER 0-2000 PSI .437 SAE
3	1	14170812GU	VALVE,AIR BLEED,12VDC,3/8"NPT
4	1	01170809BX	ELB90 .25 TUBE X .375 MPT SS
5	2	0117491869	TEE RUN .375 MPT X .375 FPT X.375 FPT SS
6	1	0117630800	ADAPTER, .4375 FPT X .25 MPT
7	1	1317081769	CONN -6 FLARE X .375 MNPT SS
8	1	0112021800	ELB90 .375 MNPT x .62 BARB NYLON
9	1	0204021869	ELB90 .375 TUBE x .375 MPT PLASTIC
10	2	1317021969	ELB90 6 FLARE X .375 MPT SS
11	1	0204021969	ELBOW,PP,3/8 ODx1/2 MT
12	1	0117362469	NIP HEX RED .5 MPT X .375 MPT

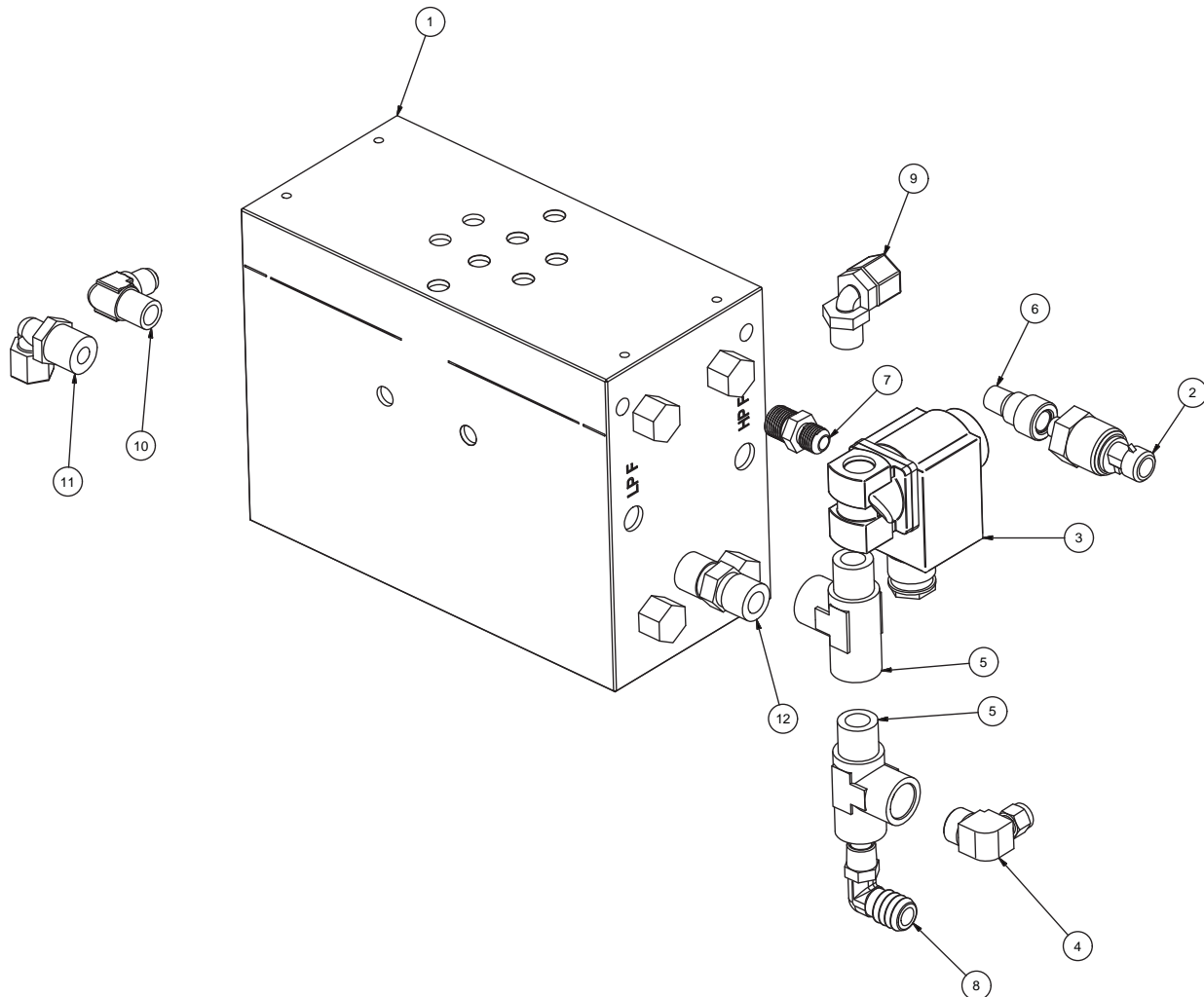

FEED PUMP UWDX-SQC 200-400 1/3HP 12VDC

ITEM NO.	QTY.	PART NUMBER	DESCRIPTION
1	1	5353140903	AQM II GP HI-PRESSURE MANIFOLD
3	1	15093110CF	MOTOR .33HP 12 VDC
4	1	12227701DP	ADAPTER PUMP ROTARY VANE
5	1	12227601DP	COUPLING PUMP-MOTOR SHAFT
6	1	2317100300	TRANSDUCER 0-2000 PSI .437 SAE
7	1	0117491869	TEE RUN .375 MPT X .375 FPT X.375 FPT SS
8	2	0112021800	ELB90 .375 MNPT x .62 BARB NYLON
9	4	061142150016	BOLT HEX _31-18 X .75
10	4	05181434AA	HOSE CLAMP .75 SS
11	4	061080056000	WASHER FLAT .38 SS
12	3	061120043000	WASHER,LOCK,1-4,SS
13	3	061142145012	BOLT HEX .25-20 X .75 SS
14	4	061142157016	BOLT HEX .375-16 X 1.0 SS
15	3	061100043000	WASHER FLAT OS .25 SS
16	1	01173818CL	NIP HEX .375 NPT X CLOSE SS

PART NUMBER: B007120002 Feed Pump Assy UWDX-SQC 200

ITEM NO.	QTY.	PART NUMBER	DESCRIPTION
2	1	12176401DP	PUMP ROTARY VANE 100 GPH #10

PART NUMBER: B007380022 Feed Pump Assy UWDX-SQC 400

ITEM NO.	QTY.	PART NUMBER	DESCRIPTION
2	1	12176402DP	PUMP ROTARY VANE 140 GPH #15

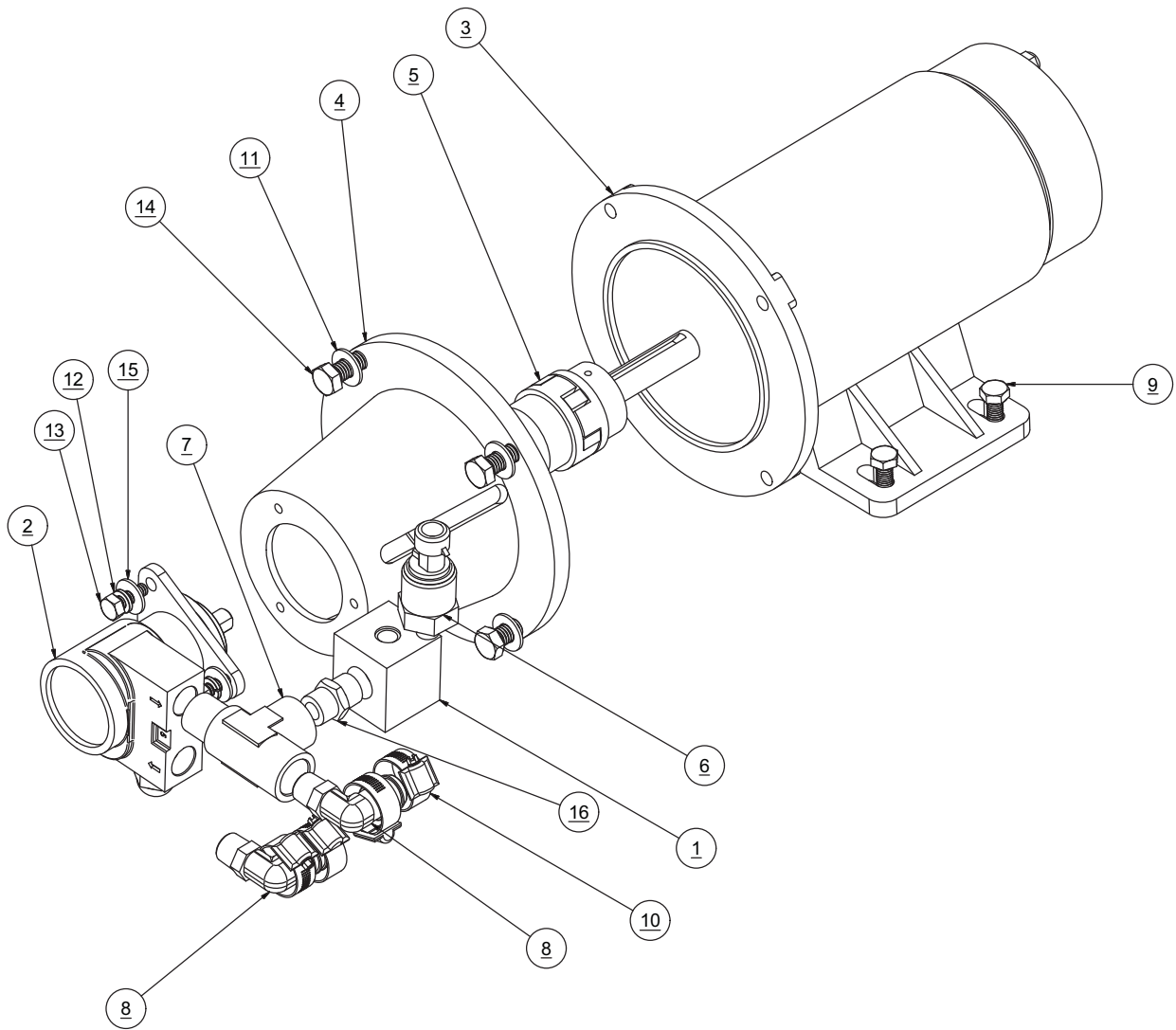

B007380023 FEED PUMP UWDX-SQC 600-12V

ITEM NO.	QTY.	PART NUMBER	DESCRIPTION
1	1	5353140903	AQM II GP HI-PRESSURE MANIFOLD
2	1	12176404DP	PUMP ROTARY VANE 215GPH #17
3	1	15153210LE	MOTOR .5 HP DC, 12V, 1800 RPM
4	1	12227701DP	ADAPTER PUMP ROTARY VANE
5	1	12227601DP	COUPLING PUMP-MOTOR SHAFT
6	1	2317100300	TRANSDUCER 0-2000 PSI .437 SAE
7	1	0117491869	TEE RUN .375 MPT X .375 FPT X.375 FPT SS
8	2	0112021800	ELB90 .375 MNPT x .62 BARB NYLON
9	4	061142150016	BOLT HEX _31-18 X .75
10	4	05181434AA	HOSE CLAMP .75 SS
11	4	061080056000	WASHER FLAT .38 SS
12	3	061120043000	WASHER,LOCK,1-4,SS
13	3	061142145012	BOLT HEX .25-20 X .75 SS
14	4	061142157016	BOLT HEX .375-16 X 1.0 SS
15	3	061100043000	WASHER FLAT OS .25 SS
16	1	01173818CL	NIP HEX .375 NPT X CLOSE SS

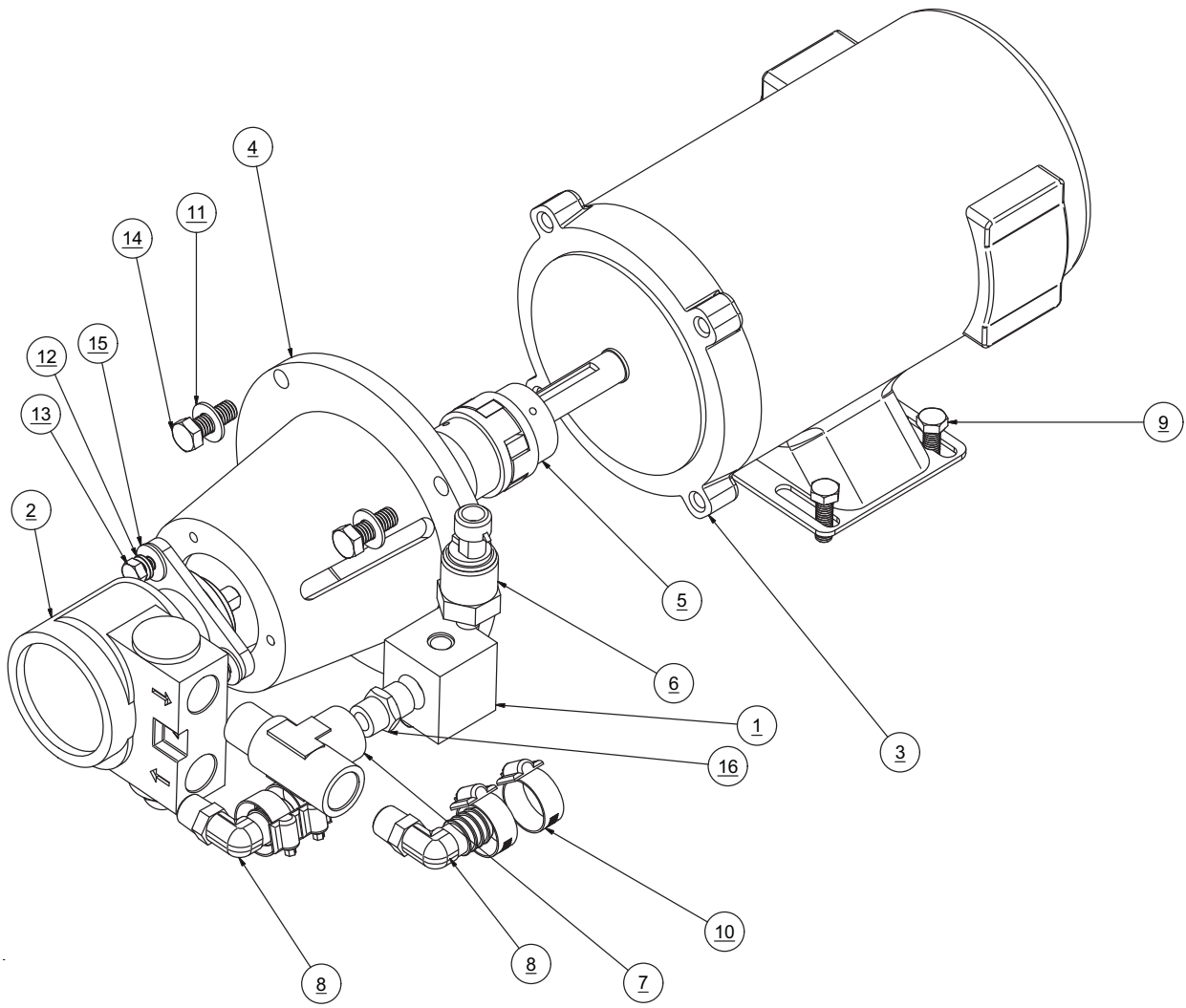

FEED PUMP UWDX-SQC 200-400 1/3HP 24VDC

ITEM NO.	QTY.	PART NUMBER	DESCRIPTION
1	1	5353140903	AQM II GP HI-PRESSURE MANIFOLD
3	1	15103210CF	MOTOR .33HP 24 VDC
4	1	12227701DP	ADAPTER PUMP ROTARY VANE
5	1	12227601DP	COUPLING PUMP-MOTOR SHAFT
6	1	2317100300	TRANSDUCER 0-2000 PSI .437 SAE
7	1	0117491869	TEE RUN .375 MPT X .375 FPT X.375 FPT SS
8	2	0112021800	ELB90 .375 MNPT x .62 BARB NYLON
9	4	061142150016	BOLT HEX _31-18 X .75
10	4	05181434AA	HOSE CLAMP .75 SS
11	4	061080056000	WASHER FLAT .38 SS
12	3	061120043000	WASHER,LOCK,1-4,SS
13	3	061142145012	BOLT HEX .25-20 X .75 SS
14	4	061142157016	BOLT HEX .375-16 X 1.0 SS
15	3	061100043000	WASHER FLAT OS .25 SS

PART NUMBER: B007120003 Feed Pump Assy UWDX-SQC 200

ITEM NO.	QTY.	PART NUMBER	DESCRIPTION
2	1	12176401DP	PUMP ROTARY VANE 100 GPH #10

PART NUMBER: B007120004 Feed Pump Assy UWDX-SQC 400

ITEM NO.	QTY.	PART NUMBER	DESCRIPTION
2	1	12176402DP	PUMP ROTARY VANE 140 GPH #15

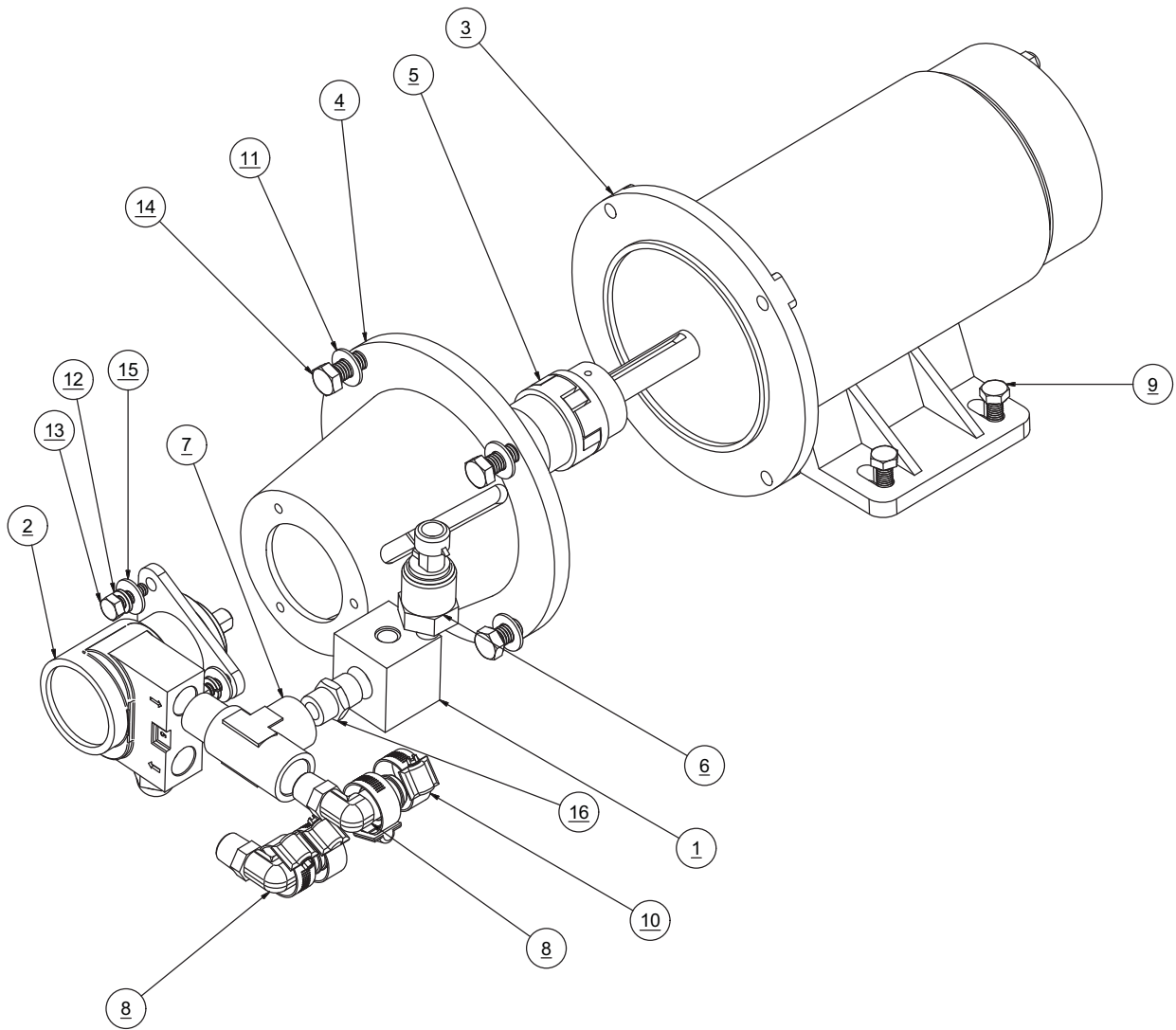

B007380024 FEED PUMP UWDX-SQC 600 1/2 24VDC

ITEM NO.	QTY.	PART NUMBER	DESCRIPTION
1	1	5353140903	AQM II GP HI-PRESSURE MANIFOLD
2	1	12176404DP	PUMP ROTARY VANE 215GPH #17
3	1	15163210LE	MOTOR .5 HP DC, 24V, 1800RPM
4	1	12227701DP	ADAPTER PUMP ROTARY VANE
5	1	12227601DP	COUPLING PUMP-MOTOR SHAFT
6	1	2317100300	TRANSDUCER 0-2000 PSI .437 SAE
7	1	0117491869	TEE RUN .375 MPT X .375 FPT X.375 FPT SS
8	2	0112021800	ELB90 .375 MNPT x .62 BARB NYLON
9	4	061142150016	BOLT HEX _31-18 X .75
10	4	05181434AA	HOSE CLAMP .75 SS
11	4	061080056000	WASHER FLAT .38 SS
12	3	061120043000	WASHER,LOCK,1-4,SS
13	3	061142145012	BOLT HEX .25-20 X .75 SS
14	4	061142157016	BOLT HEX .375-16 X 1.0 SS
15	3	061100043000	WASHER FLAT OS .25 SS
16	1	01173818CL	NIP HEX .375 NPT X CLOSE SS

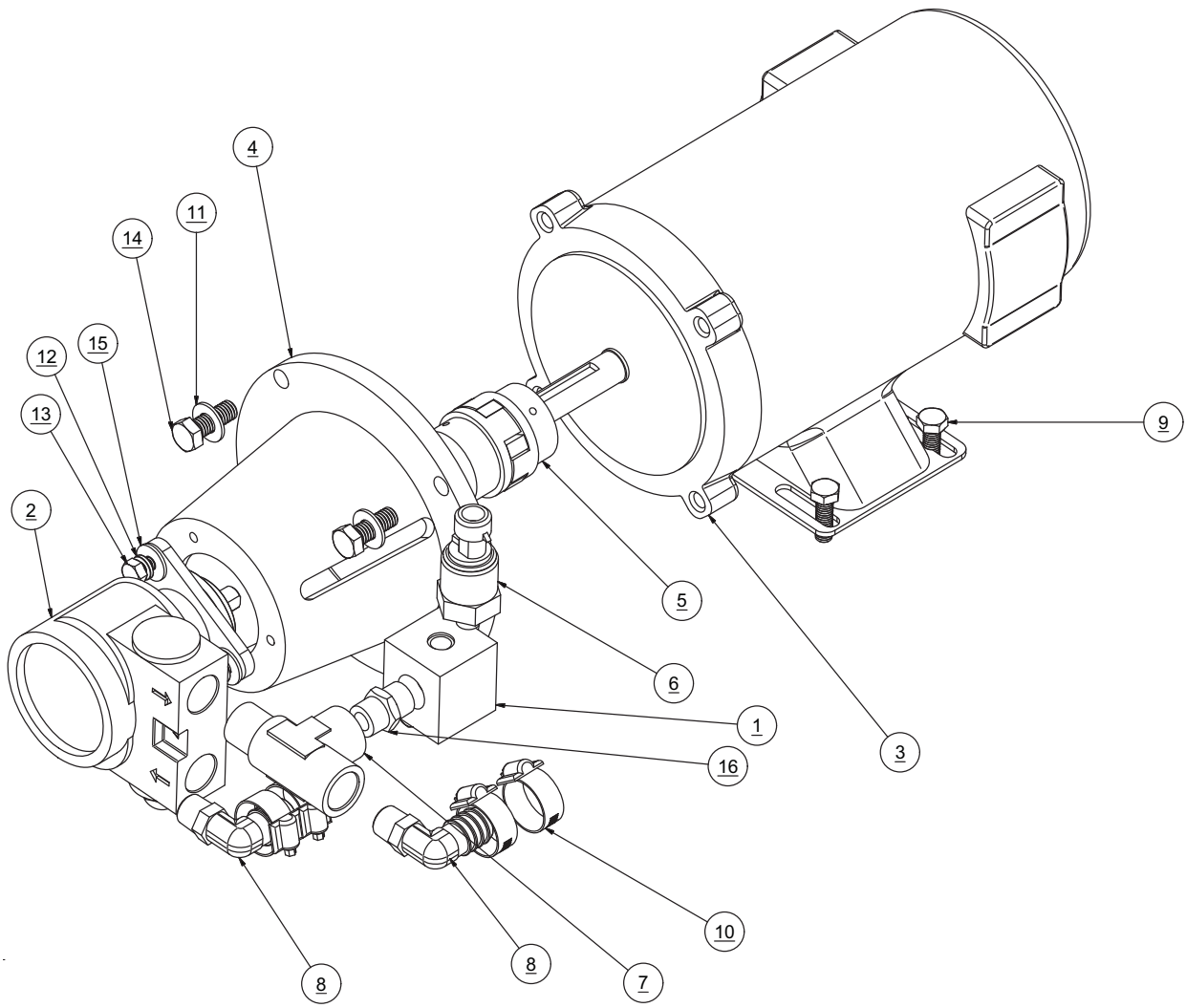

FEED PUMP SQM 200-400 1/3 12VDC- MODULAR UNIT

ITEM NO.	QTY.	PART NUMBER	DESCRIPTION
1	1	5353140903	AQM II GP HI-PRESSURE MANIFOLD
2	1	2020084006	PLATE BASE MOTOR 3PH AQMC
4	1	15093110CF	MOTOR .33HP 12 VDC
5	4	2115030120	RUBBER MOUNT 55 AQUA SERIES
6	1	12227701DP	ADAPTER PUMP ROTARY VANE
7	1	12227601DP	COUPLING PUMP-MOTOR SHAFT
8	1	2317100300	TRANSDUCER 0-2000 PSI .437 SAE
9	1	0117491869	TEE RUN .375 MPT X .375 FPT X.375 FPT SS
10	1	01173818CL	NIP HEX .375 NPT X CLOSE SS
11	2	0112021800	ELB90 .375 MNPT x .62 BARB NYLON
12	4	05181434AA	HOSE CLAMP .75 SS
13	4	061080056000	WASHER FLAT .38 SS
14	3	061120043000	WASHER,LOCK,1-4,SS
15	3	061142145012	BOLT HEX .25-20 X .75 SS
16	4	061142157016	BOLT HEX .375-16 X 1.0 SS
17	4	061060050000	NUT HEX .31-18 W-INSERT SS
18	4	061161850020	SC ALLEN FLAT .31-18 X 1.25 SS
19	4	061142150012	SCREW,HEX HEAD,.31-18x0.75,SS
20	3	061100043000	WASHER FLAT OS .25 SS
21	8	061100049000	WASHER,FLAT,OS,5/16",SS

H007110002 FEED PUMP SQM 200

ITEM NO.	QTY.	PART NUMBER	DESCRIPTION
3	1	12176401DP	PUMP ROTARY VANE 100 GPH #10

H007110022 FEED PUMP SQM 400

ITEM NO.	QTY.	PART NUMBER	DESCRIPTION
3	1	12176402DP	PUMP ROTARY VANE 140 GPH #15

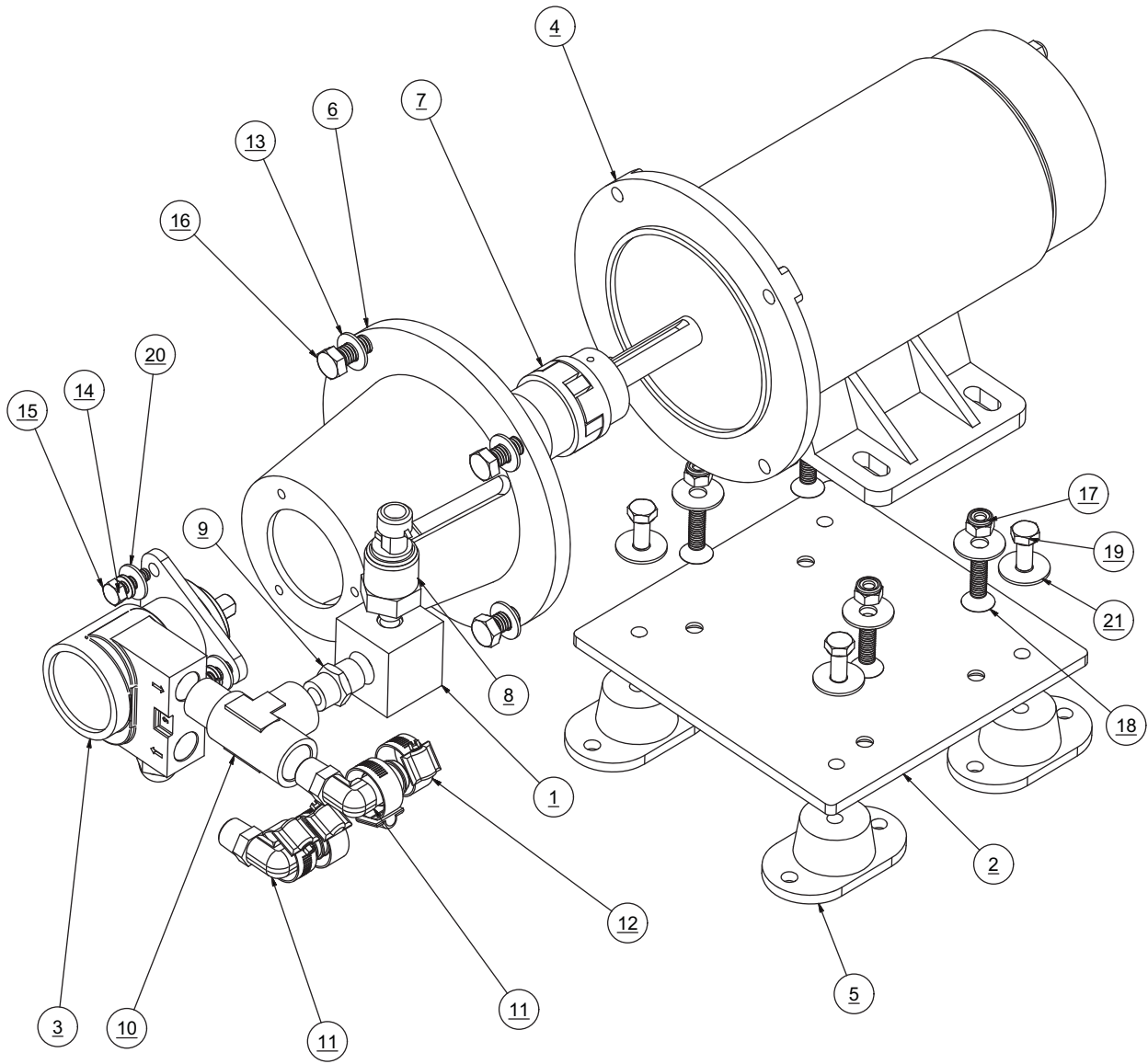

H007110023 FEED PUMP SQM 600-12V

ITEM NO.	QTY.	PART NUMBER	DESCRIPTION
1	1	5353140903	AQM II GP HI-PRESSURE MANIFOLD
2	1	2020084006	PLATE BASE MOTOR 3PH AQMC
3	1	12176404DP	PUMP ROTARY VANE 215GPH #17
4	1	15153210LE	MOTOR .5 HP DC, 12V, 1800 RPM
5	4	2115030120	RUBBER MOUNT 55 AQUA SERIES
6	1	12227701DP	ADAPTER PUMP ROTARY VANE
7	1	12227601DP	COUPLING PUMP-MOTOR SHAFT
8	1	2317100300	TRANSDUCER 0-2000 PSI .437 SAE
9	1	01173818CL	NIP HEX .375 NPT X CLOSE SS
10	1	0117491869	TEE RUN .375 MPT X .375 FPT X.375 FPT SS
11	2	0112021800	ELB90 .375 MNPT x .62 BARB NYLON
12	4	05181434AA	HOSE CLAMP .75 SS
13	4	061080056000	WASHER FLAT .38 SS
14	3	061120043000	WASHER,LOCK,1-4,SS
15	3	061142145012	BOLT HEX .25-20 X .75 SS
16	4	061142157016	BOLT HEX .375-16 X 1.0 SS
17	4	061060050000	NUT HEX .31-18 W-INSERT SS
18	4	061161850020	SC ALLEN FLAT .31-18 X 1.25 SS
19	4	061142150012	SCREW,HEX HEAD, .31-18x0.75,SS
20	3	061100043000	WASHER FLAT OS .25 SS
21	8	061100049000	WASHER,FLAT,OS,5/16",SS

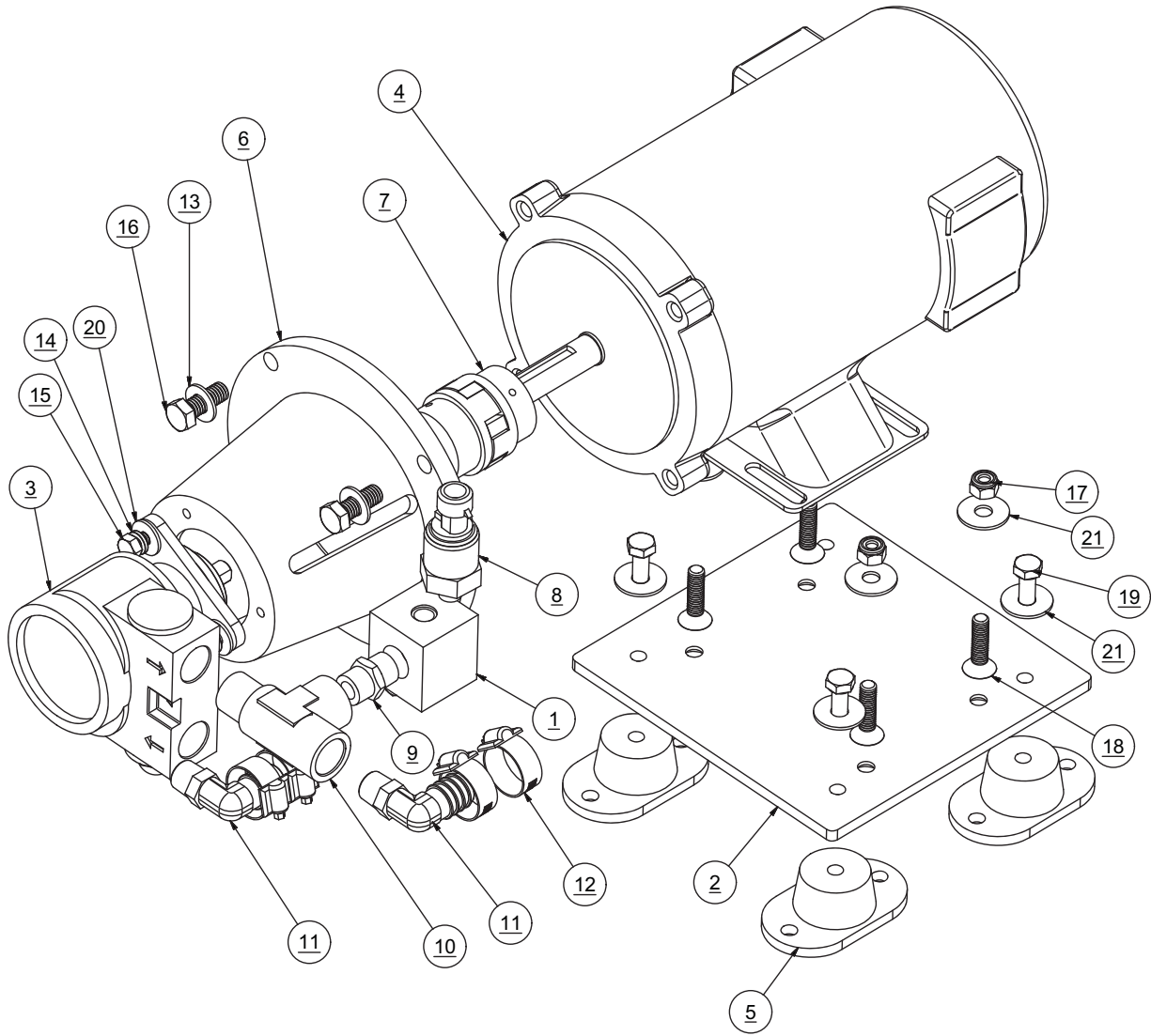

FEED PUMP SQM 200-400 1/3HP 24VDC- MODULAR UNIT

ITEM NO.	QTY.	PART NUMBER	DESCRIPTION
1	1	5353140903	AQM II GP HI-PRESSURE MANIFOLD
2	1	2020084006	PLATE BASE MOTOR 3PH AQMC
4	1	15103210CF	MOTOR .33HP 24 VDC
5	4	2115030120	RUBBER MOUNT 55 AQUA SERIES
6	1	12227701DP	ADAPTER PUMP ROTARY VANE
7	1	12227601DP	COUPLING PUMP-MOTOR SHAFT
8	1	2317100300	TRANSDUCER 0-2000 PSI .437 SAE
9	1	0117491869	TEE RUN .375 MPT X .375 FPT X.375 FPT SS
10	1	01173818CL	NIP HEX .375 NPT X CLOSE SS
11	2	0112021800	ELB90 .375 MNPT x .62 BARB NYLON
12	4	05181434AA	HOSE CLAMP .75 SS
13	4	061080056000	WASHER FLAT .38 SS
14	3	061120043000	WASHER,LOCK,1-4,SS
15	3	061142145012	BOLT HEX .25-20 X .75 SS
16	4	061142157016	BOLT HEX .375-16 X 1.0 SS
17	4	061060050000	NUT HEX .31-18 W-INSERT SS
18	4	061161850020	SC ALLEN FLAT .31-18 X 1.25 SS
19	4	061142150012	SCREW,HEX HEAD,.31-18x0.75,SS
20	3	061100043000	WASHER FLAT OS .25 SS
21	8	061100049000	WASHER,FLAT,OS,5/16",SS

PART NUMBER: H007110003 Feed Pump Assy SQM 200

ITEM NO.	QTY.	PART NUMBER	DESCRIPTION
3	1	12176401DP	PUMP ROTARY VANE 100 GPH #10

PART NUMBER: H007110004 Feed Pump Assy SQM 400

ITEM NO.	QTY.	PART NUMBER	DESCRIPTION
3	1	12176402DP	PUMP ROTARY VANE 140 GPH #15

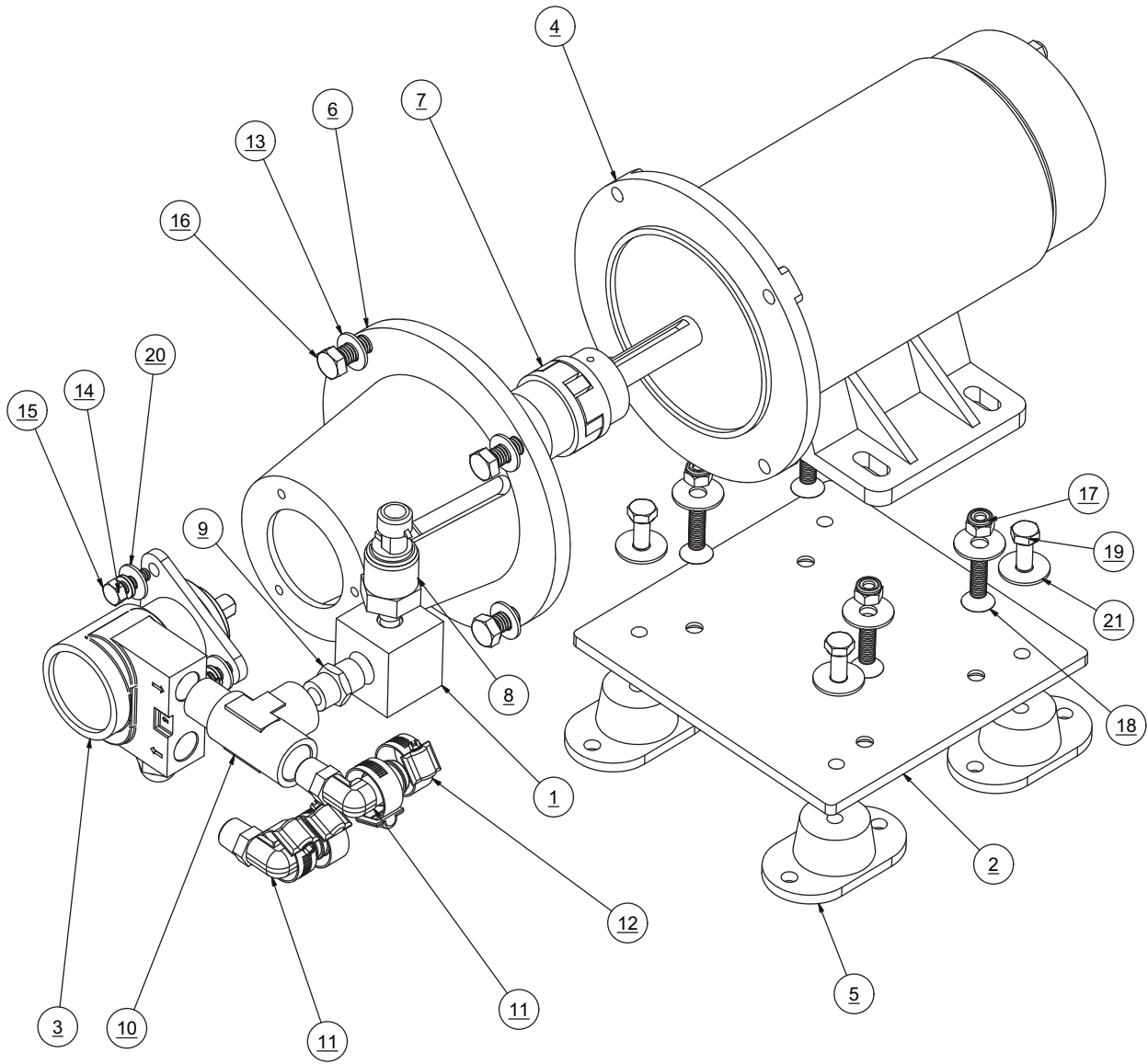

H007110024 FEED PUMP SQM 600 1/2 24VDC

ITEM NO.	QTY.	PART NUMBER	DESCRIPTION
1	1	5353140903	AQM II GP HI-PRESSURE MANIFOLD
2	1	2020084006	PLATE BASE MOTOR 3PH AQMC
3	1	12176404DP	PUMP ROTARY VANE 215GPH #17
4	1	15163210LE	MOTOR .5 HP DC, 24V, 1800RPM
5	4	2115030120	RUBBER MOUNT 55 AQUA SERIES
6	1	12227701DP	ADAPTER PUMP ROTARY VANE
7	1	12227601DP	COUPLING PUMP-MOTOR SHAFT
8	1	2317100300	TRANSDUCER 0-2000 PSI .437 SAE
9	1	01173818CL	NIP HEX .375 NPT X CLOSE SS
10	1	0117491869	TEE RUN .375 MPT X .375 FPT X.375 FPT SS
11	2	0112021800	ELB90 .375 MNPT x .62 BARB NYLON
12	4	05181434AA	HOSE CLAMP .75 SS
13	4	061080056000	WASHER FLAT .38 SS
14	3	061120043000	WASHER,LOCK,1-4,SS
15	3	061142145012	BOLT HEX .25-20 X .75 SS
16	4	061142157016	BOLT HEX .375-16 X 1.0 SS
17	4	061060050000	NUT HEX .31-18 W-INSERT SS
18	4	061161850020	SC ALLEN FLAT .31-18 X 1.25 SS
19	4	061142150012	SCREW,HEX HEAD,.31-18x0.75,SS
20	3	061100043000	WASHER FLAT OS .25 SS
21	8	061100049000	WASHER,FLAT,OS,5/16",SS

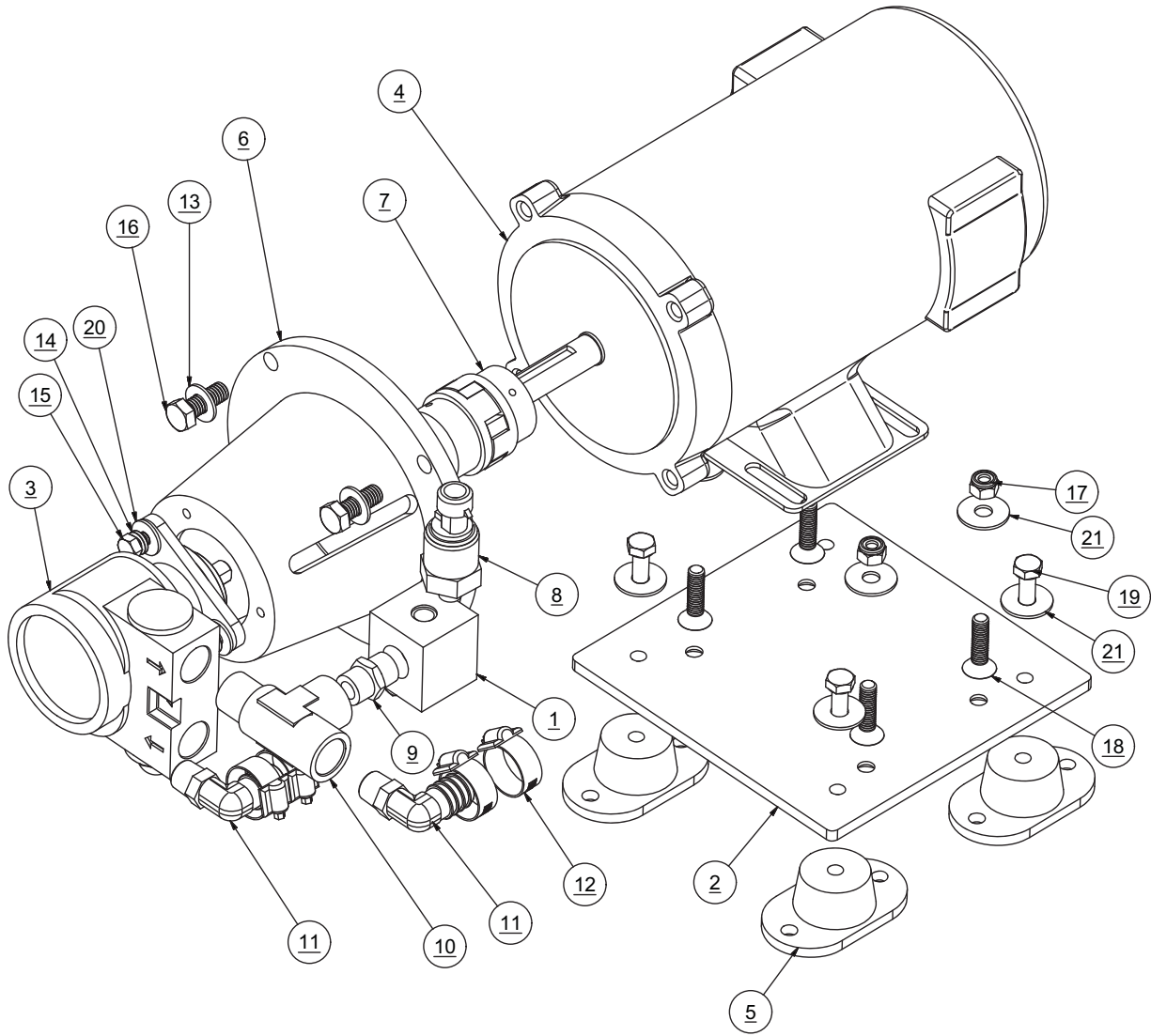

H515111002 LP BACK PLATE ASSY SQM

ITEM NO.	QTY.	PART NUMBER	DESCRIPTION
1	1	5301181000	MANIF,SP,FLOW METER,PVC
2	1	5301181100	MANIF,FLOW METER,PVC
3	1	1401096100	VALVE SOLENOID 12VDC
4	1	11026820AO	FLOW METER IN-LINE 0.26-4.0GPM
5	1	11026920AO	FLOW METER IN-LINE 0.26-4.0GPM
6	1	31316800100	PLUG DIN 4 COND
7	1	B511080004	SALINITY PROBE ASSY
8	1	0204121869	CONN .375 TUBE X .375 FPT PLASTIC
9	1	01126526DG	ADAP .5 MPT X .75 BARB NYLON
10	2	0101602583	ADAPTER 0.50 FPT X 0.50 S
11	1	0204021769	ELB90 .375 TUBE x .25 MNPT PLASTIC
12	1	0204092569	FITTING,PP,1/2 ODx1/2 MT
13	2	0204091869	FITTING,PP,3/8 ODx3/8 MT
14	1	0101378500	NIPPLE .375 NPT x 2 7/8" PVC NPT
15	1	0101312483	RB 0.50 SL x 0.38 FPT
16	1	0101322483	RB 0.50 SL x 0.38 SL
17	2	H30612730006	INSERT 8-32 X .31-18 SS
18	1	0117341869	PLUG .375 MNPT SS
19	2	061160526048	SC 8-32 x 3.00 SS
20	1	0312123569	TUBE .375 BLACK x 3.75 IN

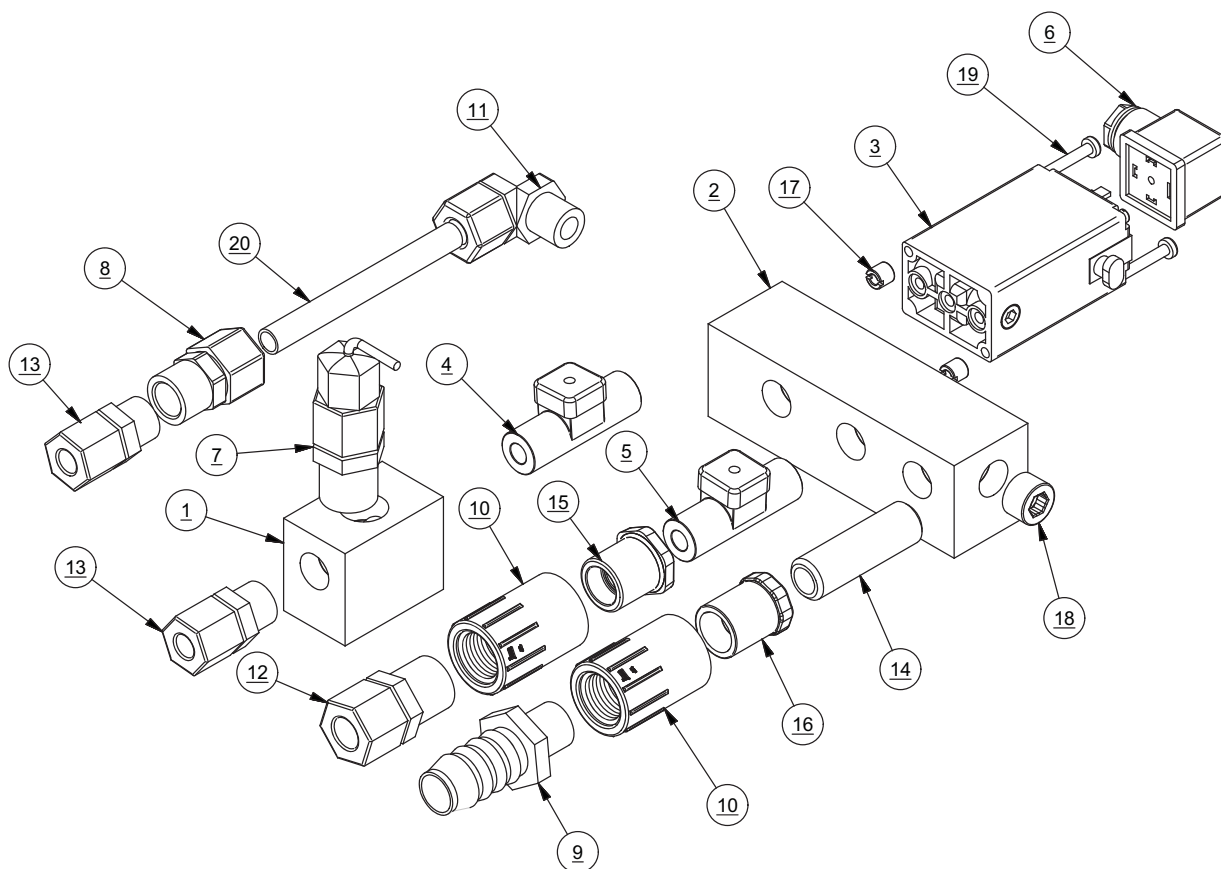

B107380004 PREFILTER ASSY UW-SE M4-600

ITEM NO.	QTY.	PART NUMBER	DESCRIPTION
1	2	07650209ST	FILTER HOUSING-LID AQUA ER
2	1	2020043809	BRACKET PREFILTER AQUA ER
3	1	05180851CC	GAUGE BRACKET CBM SS
4	1	0801060157	ELEMENT PREFILTER 10-05
5	1	0801130257	ELEMENT PREFILTER 10-25
6	2	0101072583	ELB90 0.50 MPT x 0.50 BARB
7	1	0101372515	NIPPLE 0.50 NPT x 1.50
8	1	0204010869	ELBOW,PP,1/4 ODx1/4 FT
9	4	05181434AA	HOSE CLAMP .75 SS
10	8	061170628016	SC PHIL PAN A #10 X 1 SS
11	2	061172143016	SC HEX A .25 X 1 SS
12	8	065080028000	WASHER FLAT #10 NYLON

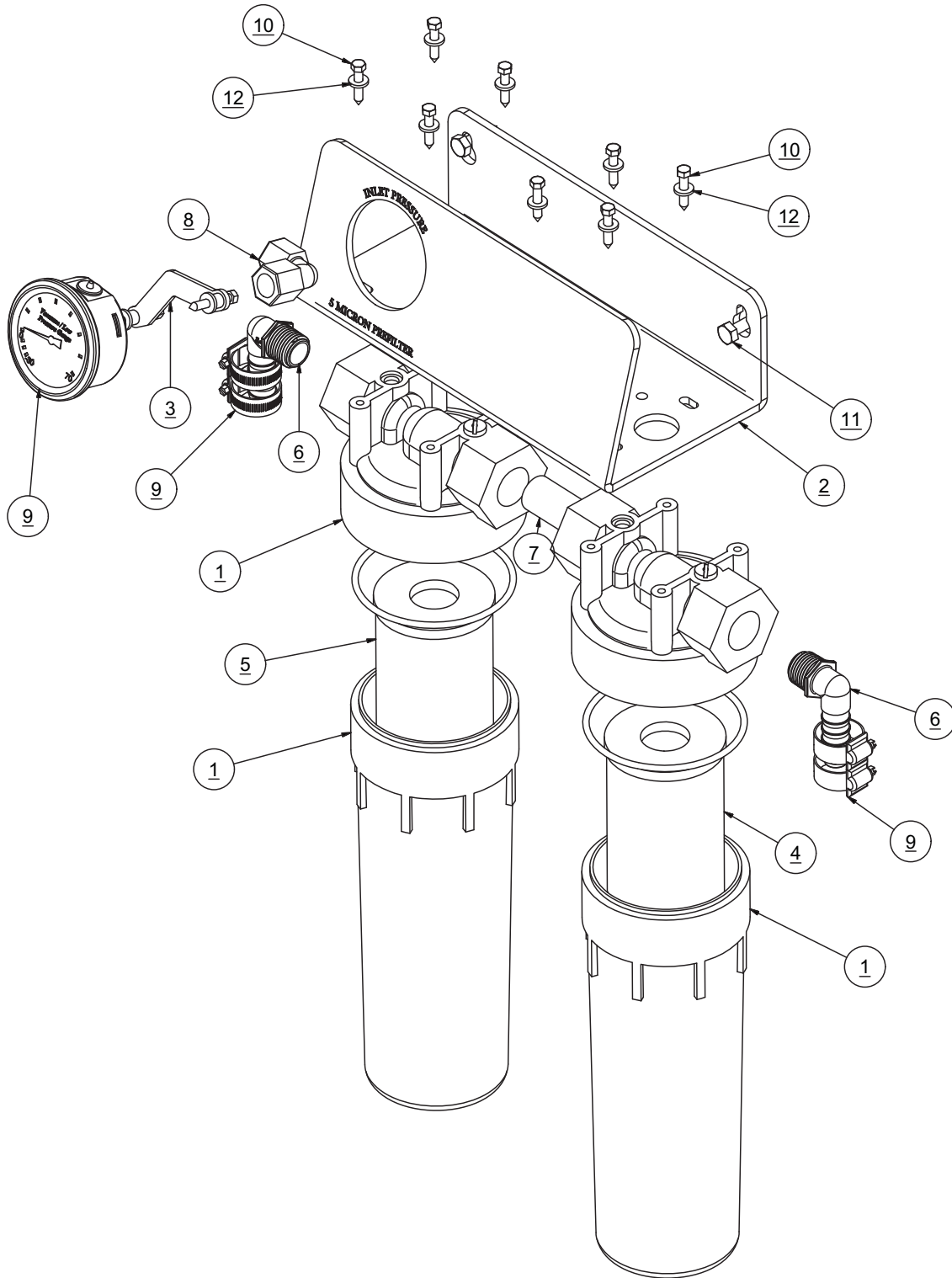

MEMBRANE VESSEL 200 - 600 GPD UWDX-SQC COMPACT

ITEM NO.	QTY.	PART NUMBER	DESCRIPTION
1	2	05202401GR	BRACKET MVA U-CLAMP
2	1	2453502400	END PLUG SINGLE 3 AW
3	2	0117410800	HP NIPPLE 0.25 MPT
4	2	0520051800-1	MVA RACK , UWDX BJ
5	2	0520210600	RETAINER PORT MVA
7	2	2615180100	FELT ADHESIVE 0.125 X 0.75 STRIP
8	1	2453512400	END PLUG DUAL 3 IN AW
10	2	1317011769	ELB90 6 FLARE X .25 FPT SS
11	1	0204010869	ELBOW,PP,1/4 ODx1/4 FT
12	1	0101370815	NIPPLE 0.25 NPT x 1.50
13	4	2614014900	O-RING 230 BRINE 3.0 END PLUG
14	4	061172143016	SCREX,HEX A,.25x1.00,SS
15	4	2614017900	O-RING 115 INTERCONNECT AW
16	2	2614010100	O-RING 116 PRODUCT AS-AW
17	4	061161845012	SC ALLEN FLAT .25-20 X .75 SS
18	6	061162345012	SC SOC CAP .25-20 X .75 SS
19	2	20201030000	SEGMENT RING AW (SET)
20	4	061080028000	WASHER FLAT #10 SS
21	1	2213017063	LABEL INLET (WHITE BACKGROUND)
22	1	2213017163	LABEL OUTLET (WHITE BACKGROUND)

B196120011 MEMBRANE VESSEL ASSY 200 GPD

ITEM NO.	QTY.	PART NUMBER	DESCRIPTION
6	1	2724011233	MEMBRANE 450GPD AW W-SEAL
9	1	2408132500	VESSEL HIGH PRESSURE 450GPD

B196120012 MEMBRANE VESSEL ASSY 400 GPD

ITEM NO.	QTY.	PART NUMBER	DESCRIPTION
6	1	2724011433	MEMBRANE 900 GPD AW W-SEAL
9	1	2408132500-02	VESSEL HIGH PRESSURE 900GPD

B196120014 MEMBRANE VESSEL ASSY 600

ITEM NO.	QTY.	PART NUMBER	DESCRIPTION
6	1	2724011433	MEMBRANE 900 GPD AW W-SEAL
9	1	2408132500-02	VESSEL HIGH PRESSURE 900GPD

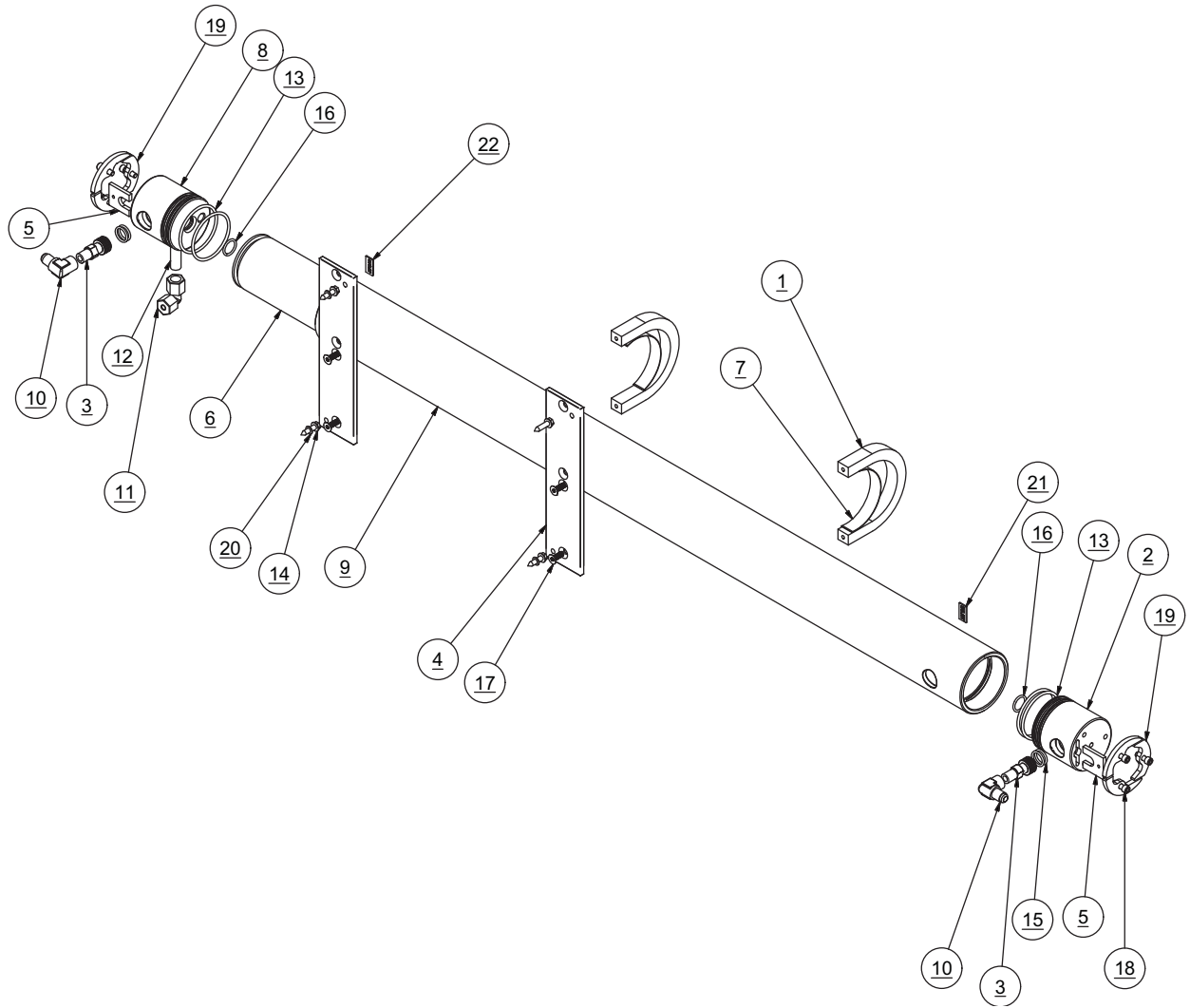

MEMBRANE VESSEL 200 - 600 GPD MODULAR

ITEM NO.	QTY.	PART NUMBER	DESCRIPTION
1	2	0520051900	MVA RACK UW-SE
2	2	0520210600	RETAINER PORT MVA
3	2	05202401GR	BRACKET,MVA U-CLAMP,3 IN
4	1	2453502400	END PLUG SINGLE 3 AW
7	1	2453512400	END PLUG DUAL 3 IN AW
8	2	2615180100	FELT ADHESIVE 0.125 X 0.75 STRIP
9	1	0101370815	NIPPLE 0.25 NPT x 1.50
10	2	0117410800	NIPPLE HP MVA AW
11	1	0204010869	ELB90 .25 TUBE x .25 FNPT PLASTIC
12	4	061172143016	SCREX,HEX A,.25x1.00,SS
13	2	1317011769	ELB90 6 FLARE X .25 FPT SS
14	2	2614010100	O-RING 116 PRODUCT AS-AW
15	4	2614014900	O-RING 230 BRINE 3.0 END PLUG
16	4	061080028000	WASHER FLAT #10 SS
17	4	061161845012	SC ALLEN FLAT .25-20 X .75 SS
18	6	061162345012	SC SOC CAP .25-20 X .75 SS
19	4	20201030000	SEGMENT RING AW (SET)
20	4	2614017900	O-RING 115 INTERCONNECT AW
21	1	2213017063	LABEL INLET (WHITE BACKGROUND)
22	1	2213017163	LABEL OUTLET (WHITE BACKGROUND)

B196380001 MEMBRANE VESSEL ASSY 200 GPD

ITEM NO.	QTY.	PART NUMBER	DESCRIPTION
5	1	2408132500	VESSEL HIGH PRESSURE 450GPD
6	1	2724011233	MEMBRANE 450GPD AW W-SEAL

B196310002 MEMBRANE VESSEL ASSY 400 GPD

ITEM NO.	QTY.	PART NUMBER	DESCRIPTION
5	1	2408132500-02	VESSEL HIGH PRESSURE 900GPD
6	1	2724011433	MEMBRANE 900 GPD AW W-SEAL

B196380003 MEMBRANE VESSEL ASSY 600

ITEM NO.	QTY.	PART NUMBER	DESCRIPTION
5	1	2408132500-02	VESSEL HIGH PRESSURE 900GPD
6	1	2724011433	MEMBRANE 900 GPD AW W-SEAL

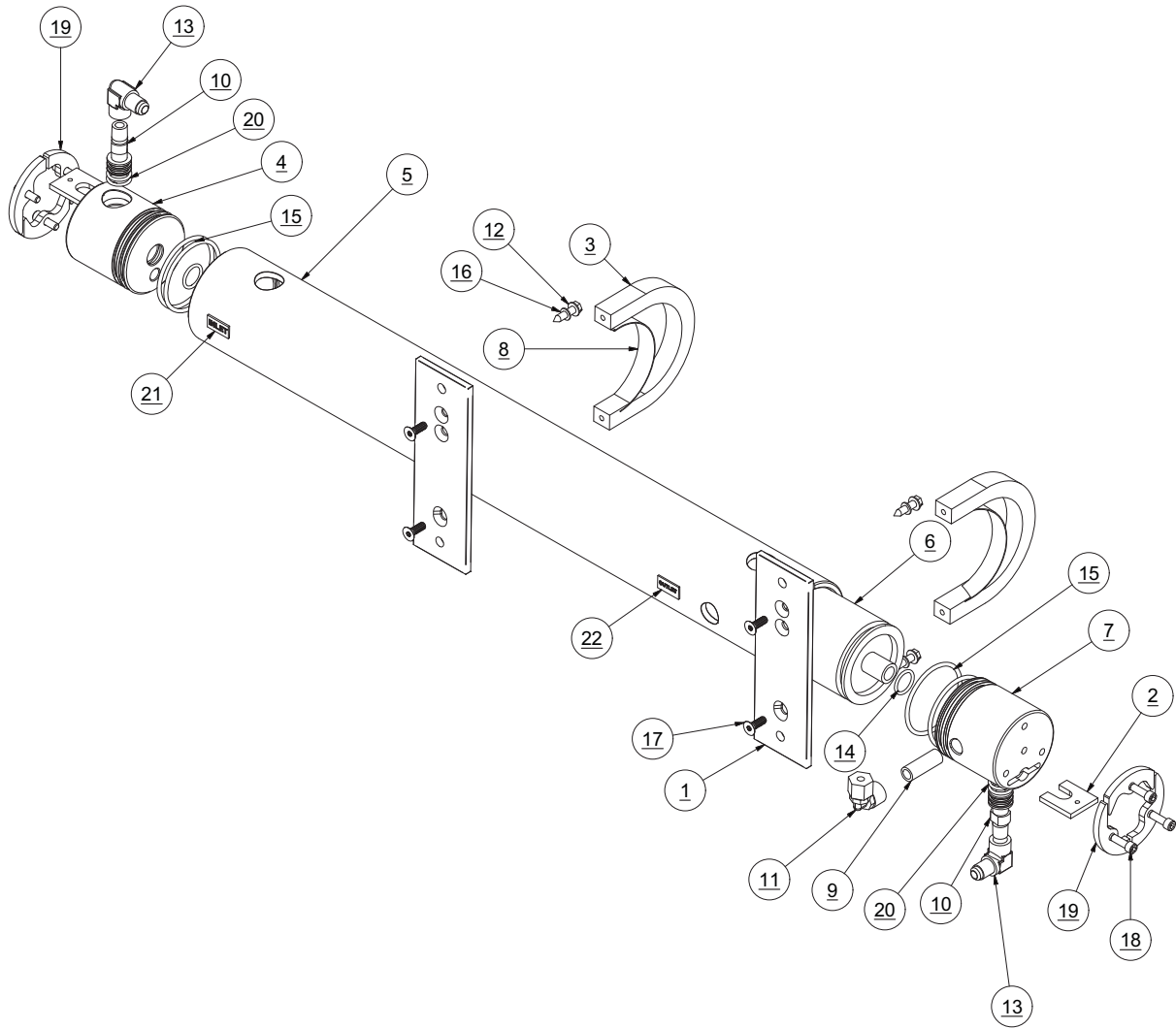

H2521210001 CHARCOAL FILTER ASSY

ITEM NO.	QTY.	PART NUMBER	DESCRIPTION
1	1	20200402102	BRACKET SINGLE FILTER
2	1	0713020573	FILTER HOUSING-LID .375 X 10 ASM
3	1	0803004773	ELEMENT CHARCOAL 10.0
5	2	0204020969	ELB90 .25 TUBE x .375 MPT PLASTIC
6	2	0204021869	ELBOW,SS,3/8 ODx3/8 MT
7	4	061170628016	SC PHIL PAN A #10 X 1 SS
8	4	061170628020	SC PHIL PAN A #10 X 1.25 SS
9	8	065080028000	WASHER FLAT #10 NYLON
10	1	2234018100	LABEL, CHARCOAL(BLUE ON WHITE)

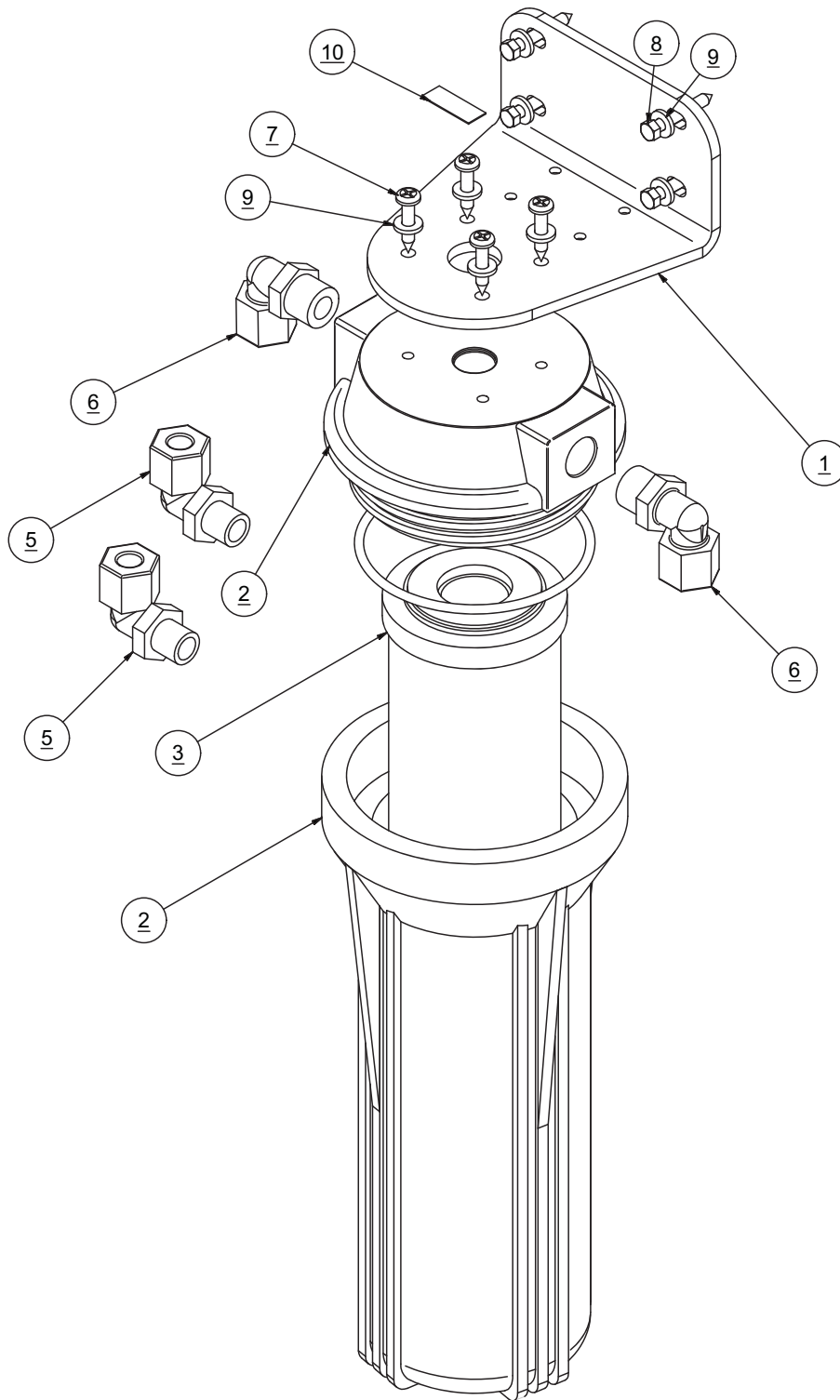

B561080001 PH NEUTRALIZER ASSY 0.5-1.5 GPM

ITEM NO.	QTY.	PART NUMBER	DESCRIPTION
1	1	20200402102	BRACKET SINGLE FILTER
2	1	0713020573	FILTER HOUSING-LID .375 X 10 ASM
3	1	08251950AS	ELEMENT POST FILTER PH 9.75 IN
4	2	0204020969	ELB90 .25 TUBE x .375 MPT PLASTIC
5	2	0204021869	ELBOW,SS,3/8 ODx3/8 MT
6	4	061172143016	SCREX,HEX A,.25x1.00,SS
7	4	061100043000	WASHER,FLAT,OS,1/4",SS
8	4	061170628016	SC PHIL PAN A #10 X 1 SS
9	1	065080028000	WASHER FLAT #10 NYLON
10	1	2224018760	LABEL,PH NEUTRALIZER

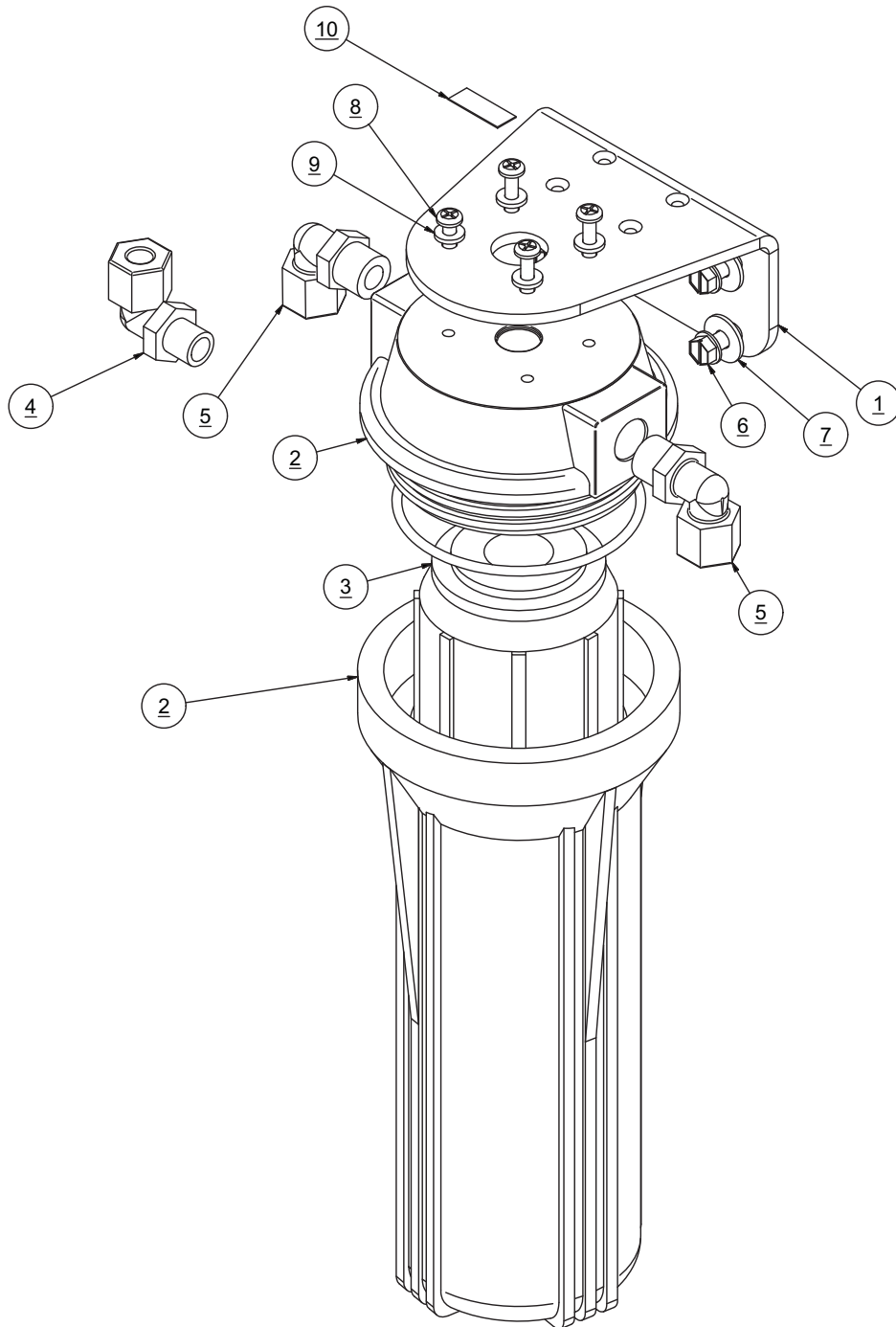
**RECOMMENDED SPARES:**

QTY.	PART NUMBER	DESCRIPTION
1	2614010473	ORING BLUE HSG 237

B591120001 CLEAN AND RINSE KIT

ITEM NO.	QTY.	PART NUMBER	DESCRIPTION
1	1	20200404040	BRACKET-CLEAN AND RINSE KIT
2	4	0101063783	ELB90 .75 FPT X .75 BARB PVC
3	2	0101613783	ADAP .75 FNPT x .75 BARB PVC
4	2	14011334AR	VALVE 3-WAY BALL .75 MPT
5	4	0501164200	PIPE SUPPORT 1.125
6	12	05181434AA	HOSE CLAMP .75 SS
7	4	061060026000	NUT,HEX,8-32 W-INSERT SS
8	4	061161626012	SC PHIL FLAT #8-32 X .75 SS
9	6	061170628016	SC PHIL PAN A #10 X 1 SS
10	6	065080028000	WASHER FLAT #10 NYLON

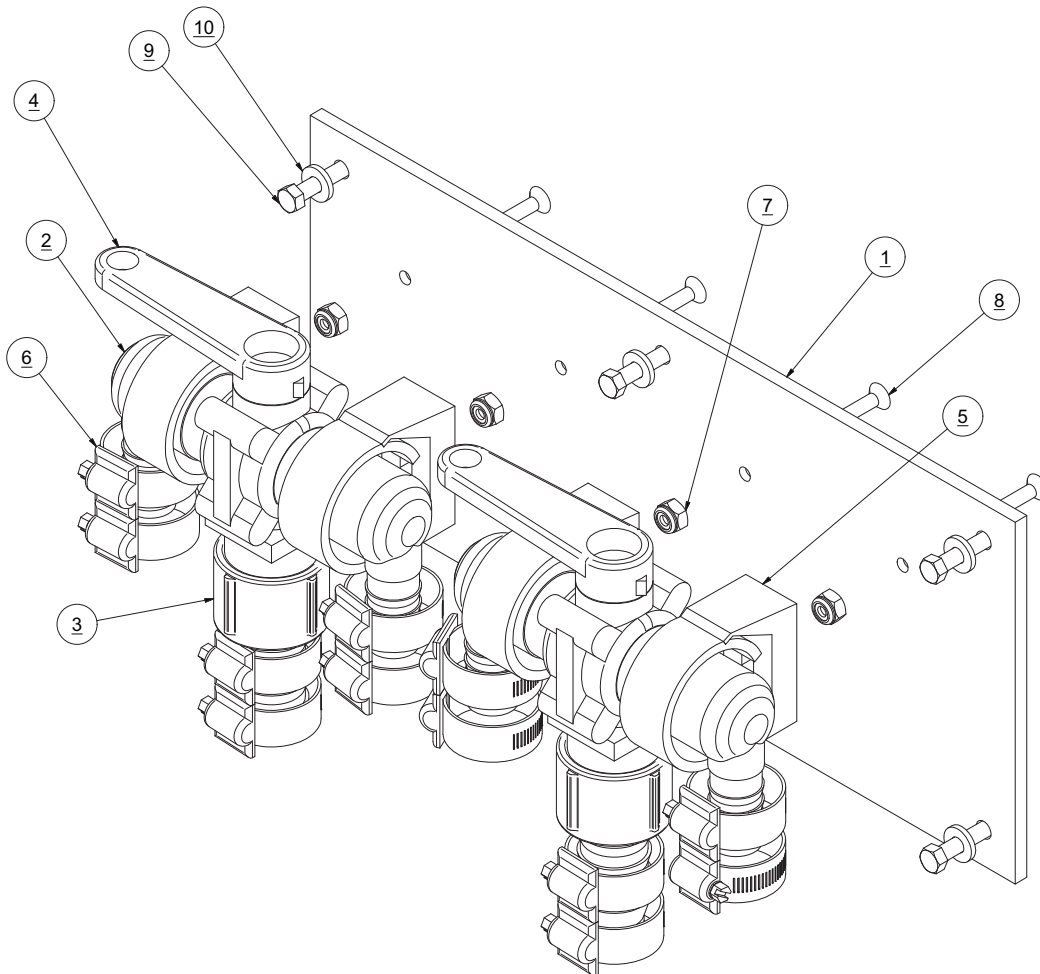

VALVE CONNECTIONS:

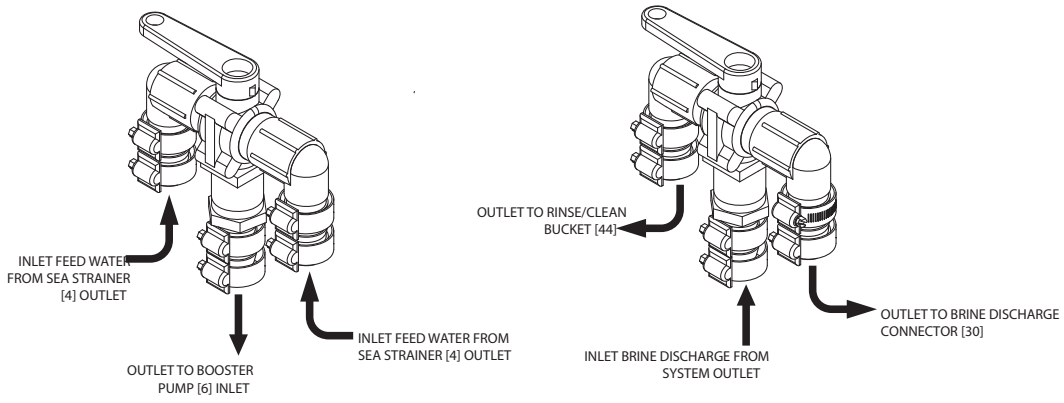

B598000005 FRESH WATER FLUSH UWDX-SQC

Select (Options):

(01) 12V, (02) 24V

ITEM NO.	QTY.	PART NUMBER	DESCRIPTION
2	1	2017043812	BRACKET FWF UW-SE
3	1	0803004473	ELEMENT CARBON BRIQUETTE 5.0 IN
4	1	2020040002	BRACKET CHECK VALVE FWF
5	1	0713020173	FILTER HOUSING-LID 0.375 X 5.0
6	2	14012118AR	VALVE CHECK 3/4" FPT WITH VITO
7	1	01129925SF	ADAPTER .50 STRAIGHT X .50 BARB
8	1	01129900SF	ELB90 .50 STRAIGHT X .50 BARB
9	3	0101653683	ADAPTER 0.75 MPT x 0.50 BARB
10	2	0112071900	ELB90 .375 MPT x .50 BARB NYLON
11	2	01013737CL	NIPPLE 0.75 NPT x CL
12	8	061172143016	SCREX,HEX A,,.25x1.00,SS
13	1	0101423783	TEE 0.75 FT x FT x FT
14	4	05181432AA	HOSE CLAMP .50
15	8	05181434AA	HOSE CLAMP .75 SS
16	1	0339076100	HOSE CLEAR BRAID .625 HDX 6.0LG
17	2	0501164500	PIPE SUPPORT 1.25
18	1	0328065066	HOSE CLEAR BRAID .50
19	4	061060031000	NUT HEX 10-32 W-INSERT SS
20	2	061060026000	NUT,HEX,8-32 W-INSERT SS
21	4	061161631020	SC PHIL FLAT #10-32 x 1.25 SS
22	2	061161626012	SC PHIL FLAT #8-32 X .75 SS
23	4	061170628016	SC PHIL PAN A #10 X 1 SS
24	4	065080028000	WASHER FLAT #10 NYLON
25	4	061080028000	WASHER FLAT #10 SS
26	8	061100043000	WASHER,FLAT,OS,1/4",SS

Option 1: Fresh Water Flush UWDX-SQC, 12V

ITEM NO.	QTY.	PART NUMBER	DESCRIPTION
1	1	12124015SF	FWF PMP/MTR 12VDC
	1	01129925SF	ADAP 1/2STRGHTx1/2BARB
	2	01129900SF	ELB90 1/2STRGHTx1/2BARB PVC
	1	0112021800	ELB90 3/8MPTx5/8BARB NYL
	1	0112071900	ELB90 3/8MPTx1/2BARB NYL

Option 2: Fresh Water Flush UWDX-SQC, 24V

ITEM NO.	QTY.	PART NUMBER	DESCRIPTION
1	1	12124016SF	FWF PMP/MTR 24VDC
	2	01129900SF	ELB90 1/2STRGHTx1/2BARB PVC
	1	01129925SF	ADAP 1/2STRGHTx1/2BARB
	1	0112021800	ELB90 3/8MPTx5/8BARB NYL

ITEM NO.	QTY.	PART NUMBER	DESCRIPTION
	1	0112071900	ELB90 3/8MPTx1/2BARB NYL

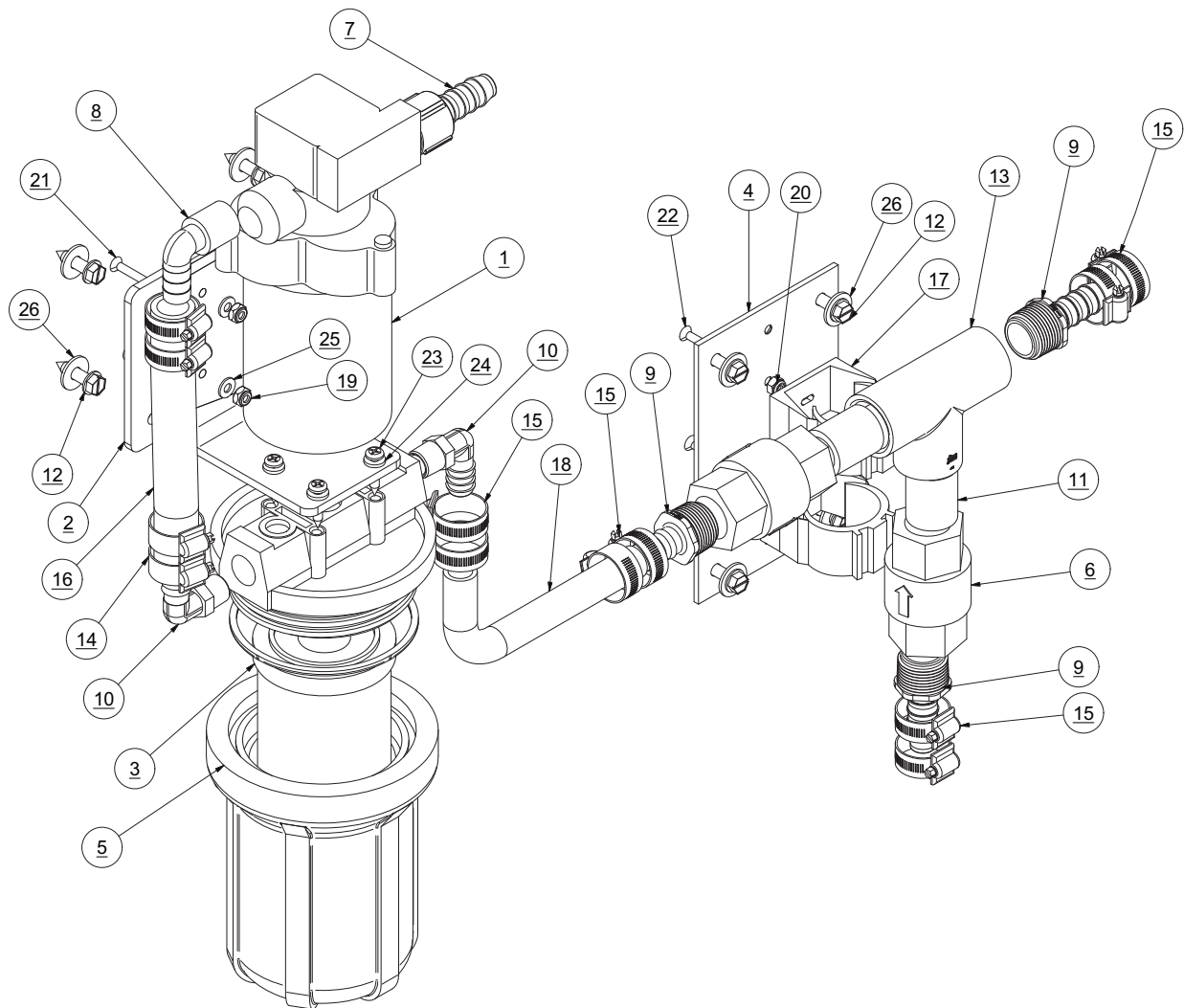

B516010001 DIVERSION VALVE ASSEMBLY

ITEM NO.	QTY.	PART NUMBER	DESCRIPTION
1	1	3131680298	PLUG CONNECTOR DIN 3-PIN
2	3	0204021769	ELB90 .375 TUBE x .25 MNPT PLASTIC
3	1	1401095998	SOLENOID VALVE EXTERNAL PORT
4	4	061170623008	SC PHIL PAN B #8 X .50 SS
5	4	065080023000	WASHER FLAT #8 NYLON

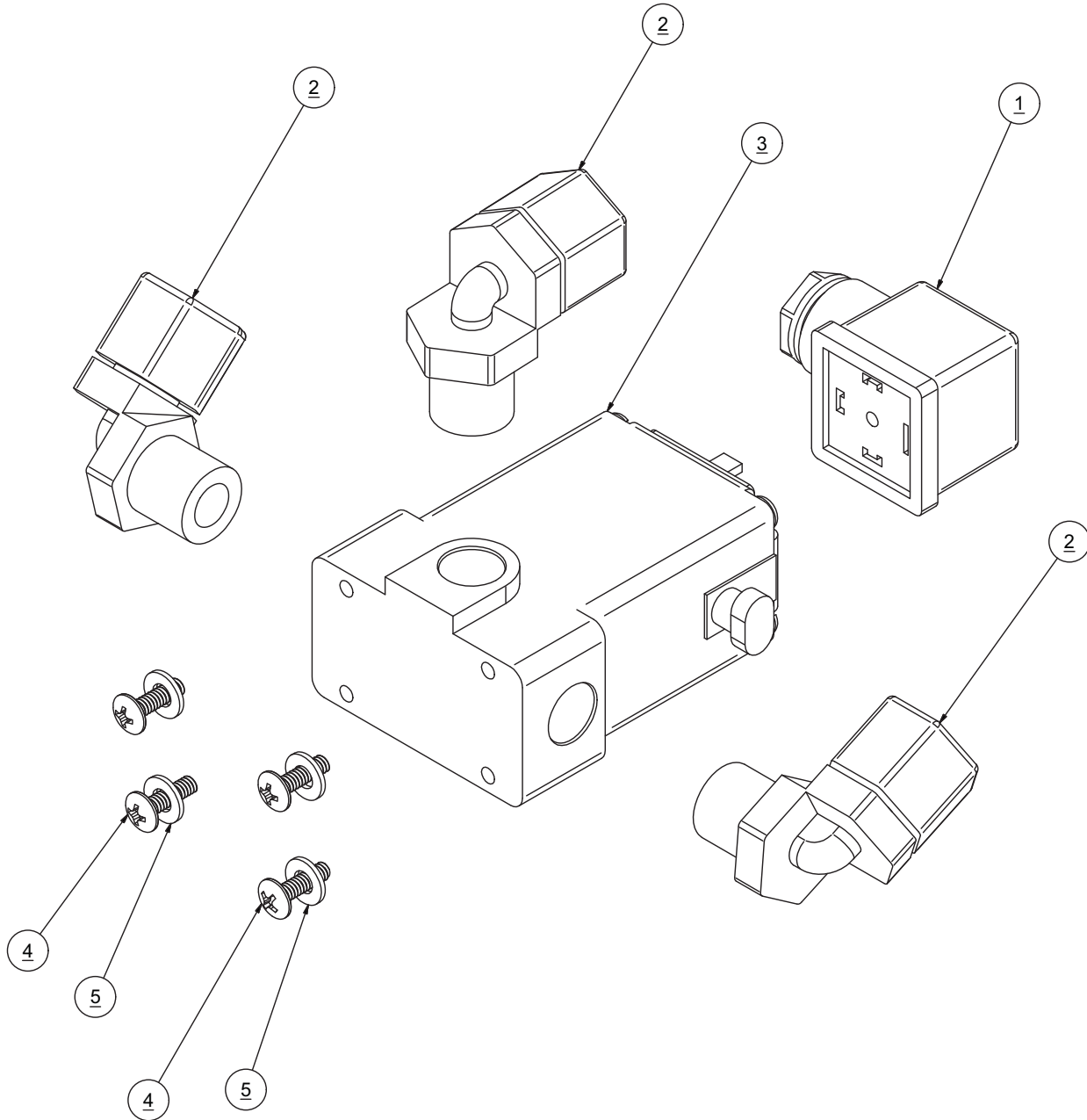

1401096100 3-WAY PRODUCT WATER DIVERSION SOLENOID VALVE

PORT DESIGNATION & DESCRIPTION (WATER FLOW)

VALVE WITH PORT DESIGNATION "A" "P" "B"

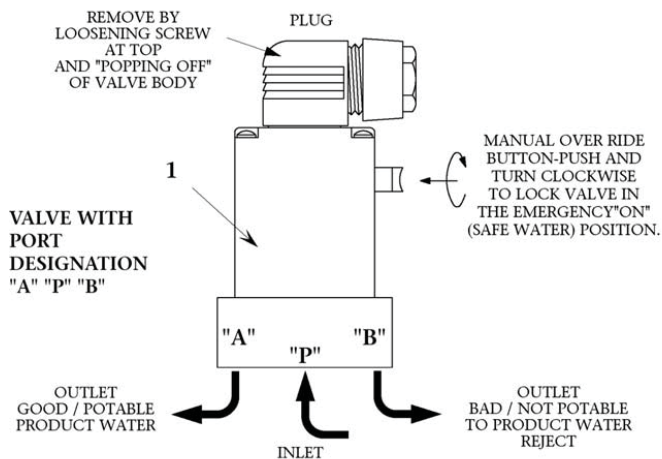

PLUMBING CONNECTIONS
 "A" = NORMALLY CLOSED -TO CHARCOAL FILTER INLET (GOOD WATER)
 "P" = INLET (COMMON)
 "B" = NORMALLY OPEN -TO DISCHARGE (BAD WATER)

VALVE WITH PORT DESIGNATION "R" "B" "P"

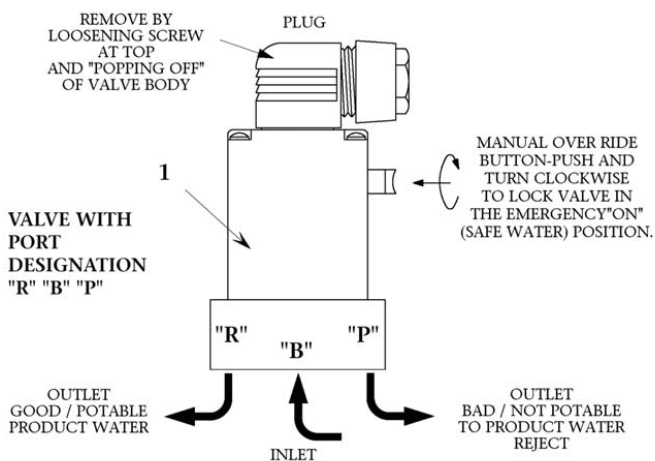

PLUMBING CONNECTIONS
 "R" = NORMALLY CLOSED -TO CHARCOAL FILTER INLET (GOOD WATER)
 "B" = INLET (COMMON)
 "P" = NORMALLY OPEN -TO DISCHARGE (BAD WATER)

B5262000CV UV STERILIZER

ITEM NO.	QTY.	PART NUMBER	DESCRIPTION
1	2	20010418001A	BRACKET MNT SADDLE UV-AW TOP
2	2	20010418002A	BRACKET MNT SADDLE UV-AW BTM
3	1	40000306CV	UV STERILIZER 2 GPM 12VDC
4	2	0204021769	ELB90 .375 TUBE x .25 MNPT PLASTIC
5	1	0204091869	FITTING,PP,3/8 ODx3/8 MT
6	2	0254011000	ELB90 0.25 MPT X 0.50BARB NY
7	4	05181432AA	CLAMP,HOSE,SS,1/2"
8	2	061100043000	WASHER,FLAT,OS,1/4",SS
9	2	061142145020	SCREW,HEX HEAD,.25-20x1-1/4",SS
10	4	061160630048	SC PHIL PAN # 10-24 X 3.00 SS
11	2	061182143024	SC LAG 0.25 X 1.50 SS
12	2	065070045000	NUT HEX .25-20 FLANGED
13	4	065080028000	WASHER FLAT #10 NYLON
14	2	2614019000	O-RING 212 QUARTZ SLEEVE
15	1	B651830001A	OWNERS MANUAL QUICK INSTALLATION UV LIGHT SP SERIES

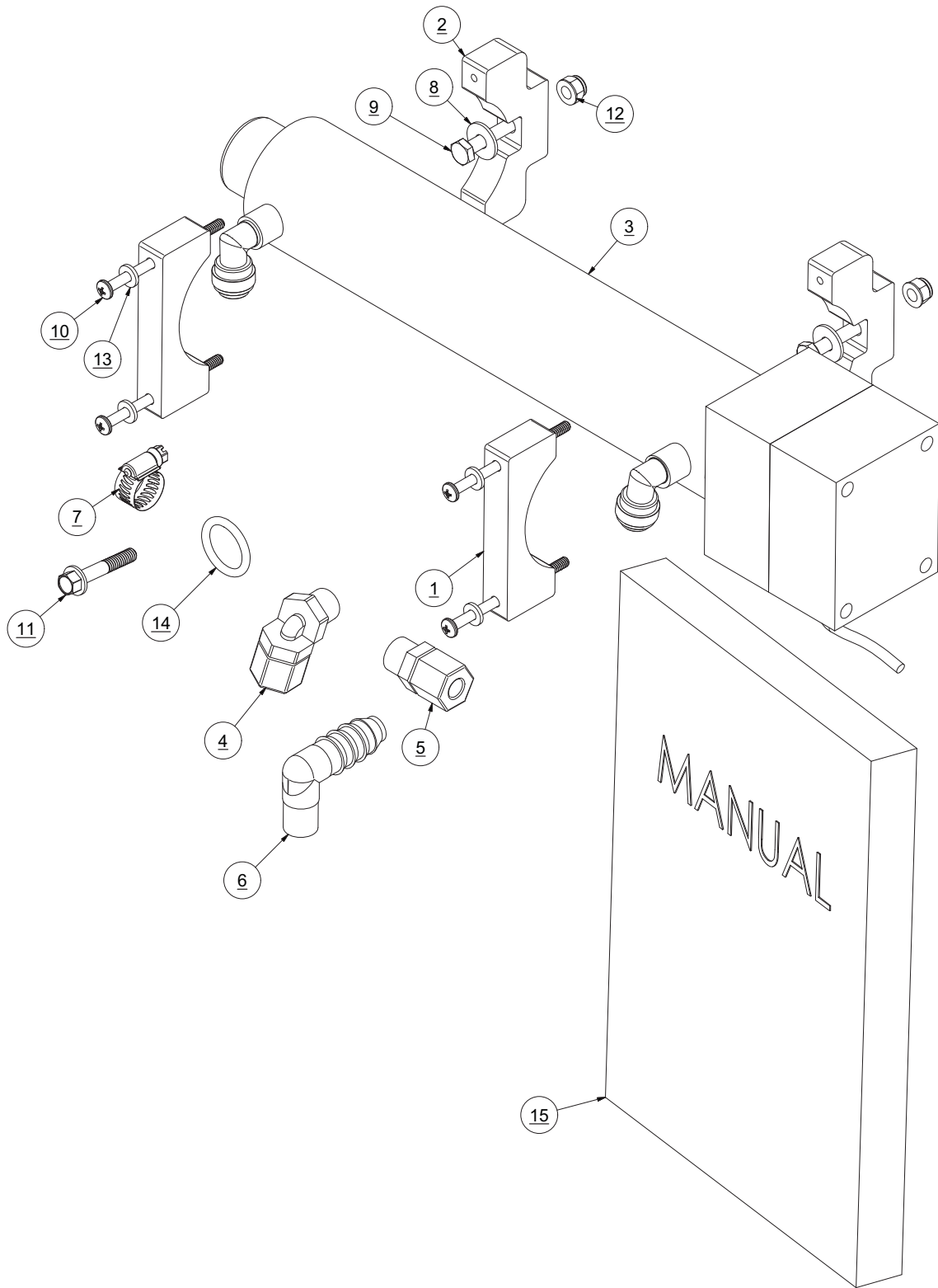

H2606210005 REMOTE ASSY HRO SF SE 170SF

ITEM NO.	QTY.	PART NUMBER	DESCRIPTION
1	1	4900283104	CABLE MULTIST 8 CON WHT
2	2	3131100900	EZ PLUG RJ45
3	1	31315609WE	REMOTE TOUCH PAD HRO

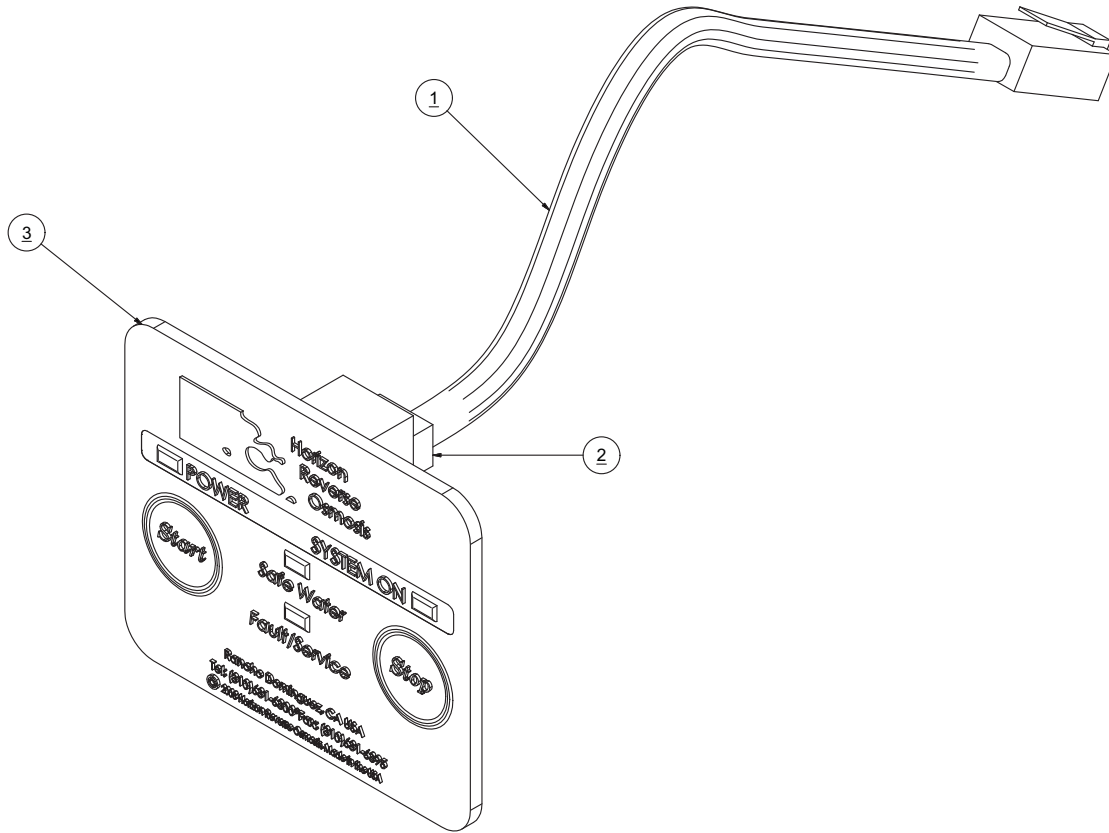

B501290001 PLUMBING ASSEMBLY UWDX-SQC

ITEM NO.	QTY.	PART NUMBER	DESCRIPTION
1	1	11026920AO	FLOW METER IN-LINE 0.26-4.0GPM
2	1	B511080004	SALINITY PROBE ASSY
3	1	11026520AO	FLOW METER IN-LINE .13-1.3GPM
4	1	0204121869	CONN .375 TUBE X .375 FPT PLASTIC
5	1	0101463783	TEE .375 FT X .375 FT X .375 FT PVC
6	3	0101551883	ADAPT .375 SL x .375 FIPT PVC
7	1	0101602583	ADAPTER 0.50 FPT X 0.50 S
8	2	0204021969	ELBOW,PP,3/8 ODx1/2 MT
9	1	0204091869	FITTING,PP,3/8 ODx3/8 MT
10	1	0101378500	NIPPLE .375 NPT x 5 PVC NPT
11	1	01173725CL	NIPPLE 0.50 NPT x CL SS
12	1	0101312483	RB 0.50 SL x 0.38 FPT
13	1	0101422583	TEE 0.50 FT x FT x FT
14	1	0501164900	SUPPORT,PIPE,0.75
15	2	0501164400	SUPPORT,PIPE,1.00
16	1	0301094100	PIPE PVC SCH 80 .375 IN x 4.06

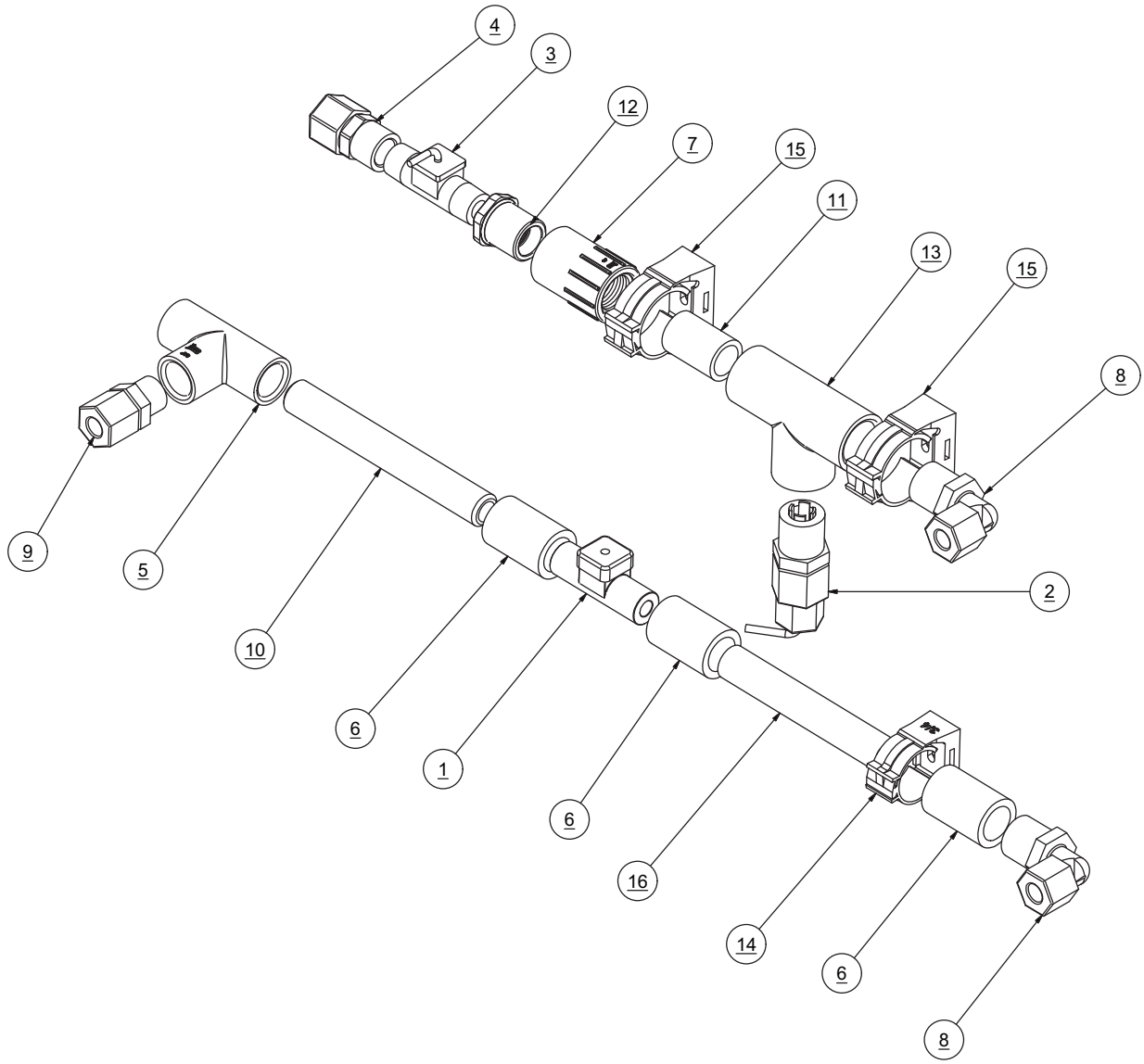

B001290002 INSTALLATION KIT UWDX

ITEM NO.	QTY.	PART NUMBER	DESCRIPTION
1	1	B006380002	SEA STRAINER ASSY UWDX 5IN
2	1	0204092069	CONN .375 TUBE X .75 MPT PLASTIC
3	1	0204091769	CONN .375 TUBE x .250 MT PLASTIC
4	1	0312121969	TUBE .25 BLAC 6 FT
5	1	0312123569	TUBE .375 BLAC 16 FT
6	10	05181434AA	HOSE CLAMP .75 SS
7	10	061172143016	SC HEX A .25 X 1 SS
8	10	061080043000	WASHER FLAT .25 SS
9	1	0328065066	HOSE CLEAR BRAID .50 12 FEET
10	1	0339076100	HOSE CLEAR BRAID .625 HD 30 FT

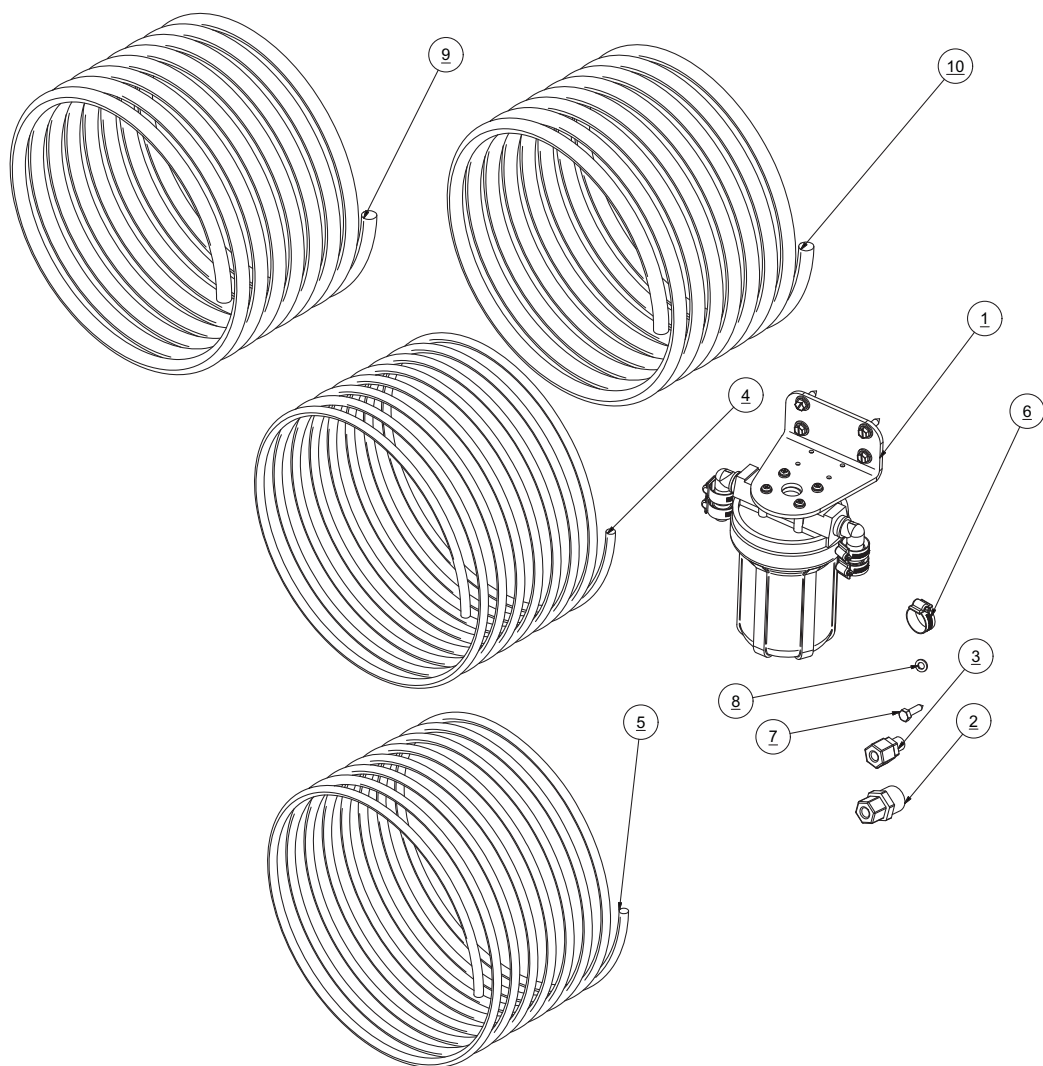

HP HOSE ASSEMBLY

ITEM NO.	QTY.	PART NUMBER	DESCRIPTION
1	1	2432160669	HOSE HP - 6P
2	2	1317481969	SWIVEL FITTING - 6 SSP

*SPECIFY PART NUMBER AND DESCRIPTION OF SPECIFIC HIGH PRESSURE HOSE ASSEMBLY
OR IF A SPECIAL LENGTH IS REQUIRED, SPECIFY MEASURED OVERALL LENGTH: FITTING TO FITTING*

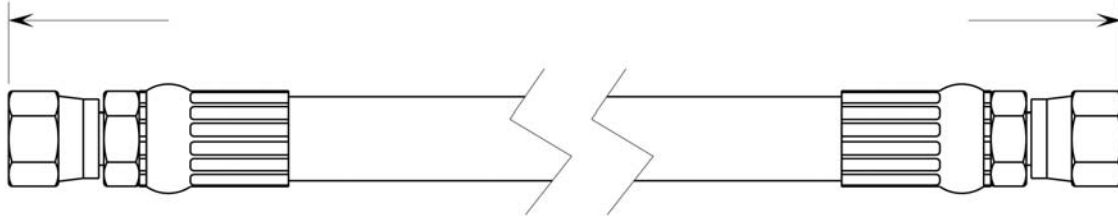

OVERALL LENGTH IS + / - 1/4" (6mm)

AVAILABLE TUBES AND FITTINGS

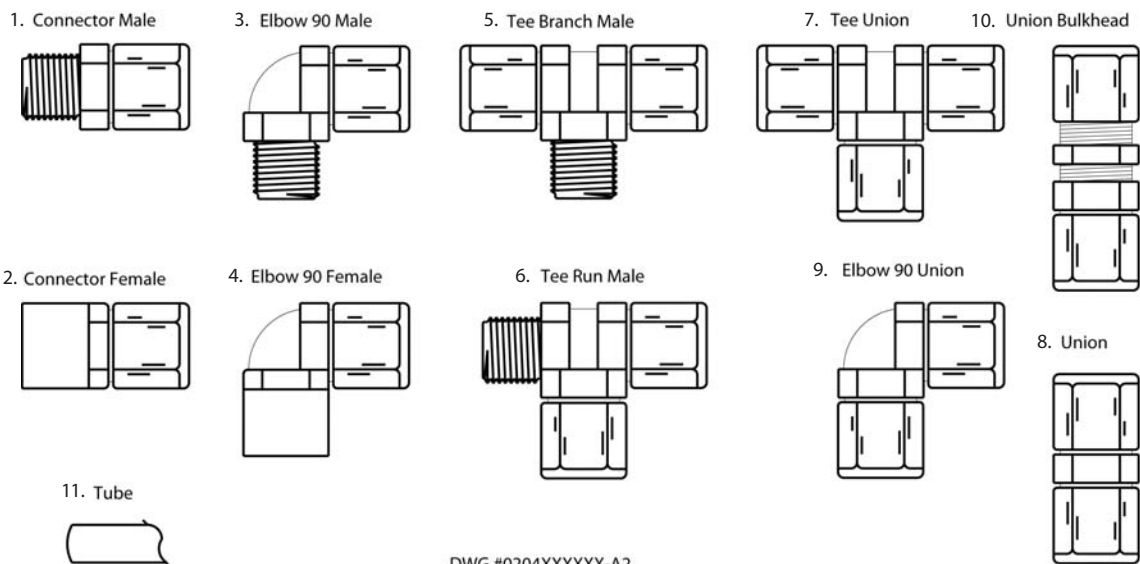

DWG #0204XXXXXX-A2

PART NO	DESCRIPTION
1. CONNECTOR MALE	
0204090669	1/4 inch tube x 1/8 inch mnpt
0204090869	1/4 inch tube x 1/4 inch mnpt
0204091669	3/8 inch tube x 1/8 inch mnpt
0204091769	3/8 inch tube x 1/4 inch mnpt
0204091869	3/8 inch tube x 3/8 inch mnpt
0204091969	3/8 inch tube x 1/2 inch mnpt
0204092069	3/8 inch tube x 3/4 inch mnpt
0204092269	1/2 inch tube x 1/8 inch mnpt
0204092369	1/2 inch tube x 1/4 inch mnpt
0204092469	1/2 inch tube x 3/8 inch mnpt
0204092569	1/2 inch tube x 1/2 inch mnpt
0204092669	1/2 inch tube x 3/4 inch mnpt
0204099069	5/8 inch tube x 1/8 inch mnpt
0204099169	5/8 inch tube x 1/4 inch mnpt
0204092869	5/8 inch tube x 3/8 inch mnpt
0204092969	5/8 inch tube x 1/2 inch mnpt
0204093169	5/8 inch tube x 3/4 inch mnpt
2. CONNECTOR FEMALE	
0204120669	1/4 inch tube x 1/8 inch fnpt
0204120869	1/4 inch tube x 1/4 inch fnpt
0204121769	3/8 inch tube x 1/4 inch fnpt
0204121869	3/8 inch tube x 3/8 inch fnpt
0204121969	3/8 inch tube x 1/2 inch fnpt
0204122569	1/2 inch tube x 1/2 inch fnpt
0204122669	1/2 inch tube x 3/4 inch fnpt

PART NO	DESCRIPTION
0204122969	5/8 inch tube x 1/2 inch fnpt
3. ELBOW 90 MALE	
0204020669	1/4 inch tube x 1/8 inch mnpt
0204020869	1/4 inch tube x 1/4 inch mnpt
0204020969	1/4 inch tube x 3/8 inch mnpt
0204021769	3/8 inch tube x 1/4 inch mnpt
0204021869	3/8 inch tube x 3/8 inch mnpt
0204021969	3/8 inch tube x 1/2 inch mnpt
0204022069	3/8 inch tube x 3/4 inch mnpt
0204022469	1/2 inch tube x 3/8 inch mnpt
0204022569	1/2 inch tube x 1/2 inch mnpt
0204022969	5/8 inch tube x 1/2 inch mnpt
4. ELBOW 90 FEMALE	
0204010669	1/4 inch tube x 1/8 inch fnpt
0204010869	1/4 inch tube x 1/4 inch fnpt
0204011769	3/8 inch tube x 1/4 inch fnpt
0204011869	3/8 inch tube x 3/8 inch fnpt
0204012469	1/2 inch tube x 3/8 inch fnpt
0204012569	1/2 inch tube x 1/2 inch fnpt
0204012969	5/8 inch tube x 1/2 inch fnpt
5. RUN TEE MALE	
0204150669	1/4 inch tube x 1/8 inch mnpt
0204151769	3/8 inch tube x 1/4 inch mnpt
0204152469	1/2 inch tube x 3/8 inch mnpt
0204152969	5/8 inch tube x 1/2 inch mnpt
6. BRANCH TEE MALE	
0204170669	1/4 inch tube x 1/8 inch mnpt
0204170869	1/4 inch tube x 1/4 inch mnpt
0204171769	3/8 inch tube x 1/4 inch mnpt
0204171869	3/8 inch tube x 3/8 inch mnpt
0204172469	1/2 inch tube x 3/8 inch mnpt
0204172569	1/2 inch tube x 1/2 inch mnpt
0204172969	5/8 inch tube x 1/2 inch mnpt
7. UNION TEE	
0204240869	1/4 inch tube
0204241869	3/8 inch tube
0204242469	1/2 inch tube x 3/8 inch tube
0204242569	1/2 inch tube
0204242869	5/8 inch tube x 3/8 inch tube
0204243069	5/8 inch tube
8. UNION	
0204210869	1/4 inch tube
0204211769	3/8 inch tube x 1/4 inch tube

PART NO	DESCRIPTION
0204211869	3/8 inch tube
0204212469	1/2 inch tube x 3/8 inch tube
0204212569	1/2 inch tube
0204212869	5/8 inch tube x 3/8 inch tube
0204212969	5/8 inch tube x 1/2 inch tube
0204213069	5/8 inch tube
9. UNION ELBOW 90	
0204220869	1/4 inch tube
0204221769	3/8 inch tube x 1/4 inch tube
0204221869	3/8 inch tube
0204222569	1/2 inch tube
0204223069	5/8 inch tube
10. UNION BULKHEAD	
0204270869	1/4 inch tube
0204271869	3/8 inch tube
0204272569	1/2 inch tube
11. TUBE	
0312121969	1/4 inch tube Black Nylon
0306152969	1/4 inch tube Blue Polypropylene
0306142969	1/4 inch tube Red Polypropylene
0312124169	3/8 inch tube Black Nylon
0306154169	3/8 inch tube Blue Polypropylene
0306144169	3/8 inch tube Red Polypropylene
0312124269	1/2 inch tube Black Nylon
0305125169	5/8 inch tube Black Polypropylene

TUBE COMPRESSION FITTINGS REPLACEMENT PARTS

ITEM	DESCRIPTION	PART NO.
FOR 1/4" O.D. TUBE		
1	NUT/SPACER/GRAB & O-RING 1/4"	0204-1/469
2	TUBE 1/4 BLACK	0312121969
FOR 3/8" O.D. TUBE		
1	NUT/SPACER/GRAB & O-RING 3/8"	0204-3/869
2	TUBE 3/8 BLACK	0312123569
FOR 1/2" O.D. TUBE		
1	NUT/SPACE/GRAB & O-RING 1/2"	0204-1/269
2	TUBE 1/2 BLACK NO SUBSTITUTE	0312124269
FOR 5/8" O.D. TUBE		
1	NUT/SPACER/GRAB & O-RING 5/8"	0204-5/869
2	TUBE 5/8 BLACK POLYPRO	0305125169

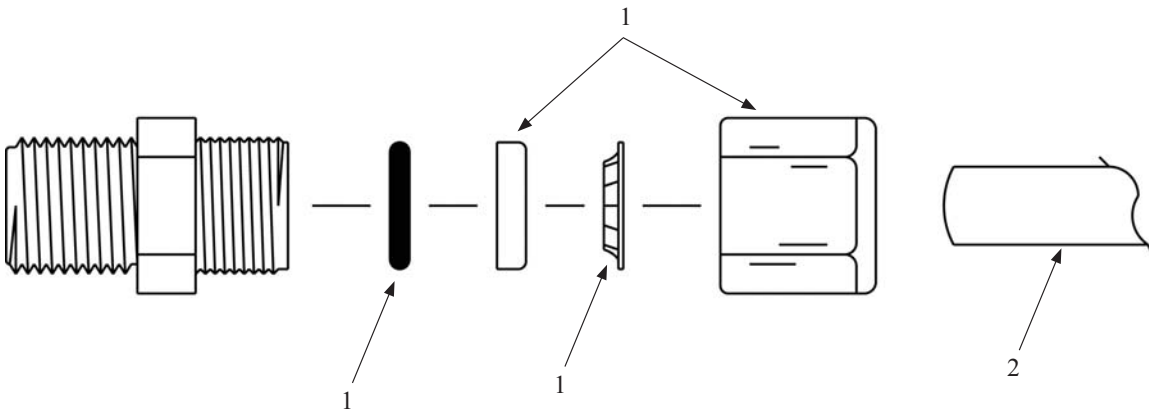

Declaration of Conformity

CE

HORIZON REVERSE OSMOSIS declares that the following models conform to the EN 55011A and EN 50082-2 standards:

Product Series:

Horizon Seafari Versatile Series
Horizon Seafari Mini Series
Horizon Seafari Quest Series

Model Names:

Seafari Versatile
Seafari Mini
Seafari Quest



Manufacturer's Name:
Horizon Reverse Osmosis
Manufacturer's Address:
2630 E. El Presidio St.
Carson, CA 90810
U.S.A.



Official Seal

Supplementary Information:

"The product complies with the Requirements of the EMC Directive 89/336/EEC."

Lisa Gomez
Quality & Environmental Manager
Manufacturer's Contact



Confirmation of Product Type Approval 22/FEB/2011

Please refer to the "Service Restrictions" shown below to determine if Unit Certification is required for this product.

This is to certify that, pursuant to the Rules of the American Bureau of Shipping (ABS), the manufacturer of the below listed product held a valid Manufacturing Assessment (MA) with expiration date of 19/MAY/2014. The continued validity of the Manufacturing Assessment is dependent on completion of satisfactory audits as required by the ABS Rules.

And; a Product Design Assessment (PDA) valid until 22/NOV/2015 subject to continued compliance with the Rules or standards used in the evaluation of the product.

The above entitle the product to be called Product Type Approved.

The Product Design Assessment is valid for products intended for use on ABS classed vessels, MODUs or facilities which are in existence or under contract for construction on the date of the ABS Rules used to evaluate the Product.

ABS makes no representations regarding Type Approval of the Product for use on vessels, MODUs or facilities built after the date of the ABS Rules used for this evaluation.

Due to wide variety of specifications used in the products ABS has evaluated for Type Approval, it is part of our contract that; whether the standard is an ABS Rule or a non-ABS Rule, the Client has full responsibility for continued compliance with the standard.

SEA RECOVERY CORP. Model Name(s): Seafari Quest

Presented to:

SEA RECOVERY CORP.
2630 E. El Presidio St.
Carson, CA 90810
United States

Intended Service:	Marine & Offshore Application - Production of Fresh Water by Sea Desalination
Description:	Reverse Osmosis Desalination Unit. See attached "pdf" product details
Ratings:	Seafari Quest 200: 8 GPH Seafari Quest 300: 13 GPH Seafari Quest 400: 17 GPH Seafari Quest 500: 21 GPH Seafari Quest 600: 25 GPH
Service Restrictions:	Unit Certification is not required for this product. If the manufacturer or purchaser request an ABS Certificate for compliance with a specification or standard, the specification or standard, including inspection standards and tolerances, must be clearly defined.
Comments:	1) The use of PVC piping is limited to 35 psi for water application.
Notes / Documentation:	Supporting Documentation: Seafari Quest 200 GPD Compact, Seafari Quest 200 GPD Modular, Seafari 350GPD Frame, Seafari (Proposed Layout).
Term of Validity:	This Product Design Assessment (PDA) Certificate 06-HS159834A-1-PDA, dated 23/Nov/2010 remains valid until 22/Nov/2015 or until the Rules or specifications used in the assessment are revised (whichever occurs first). This PDA is intended for a product to be installed on an ABS classed vessel, MODU or facility which is in existence or under contract for construction on the date of the ABS Rules or specifications used to evaluate the Product. Use of the Product on an ABS classed vessel, MODU or facility which is contracted after the validity date of the ABS Rules and specifications used to evaluate the Product, will require re-evaluation of the

ABS Rules: PDA. Use of the Product for non ABS classed vessels, MODUs or facilities is to be to an agreement between the manufacturer and intended client.
 2010 Steel Vessels Rules 1-1-4/7.7, 1-1-Appendix 3, 4-6-2/5.7

National Standards:

International Standards:

Government Authority:

EUMED:

Others: None.

Model Certificate	Model Certificate No	Issue Date	Expiry Date
PDA	06-HS159834A-1-PDA	23/NOV/2010	22/NOV/2015



ABS Programs

ABS has used due diligence in the preparation of this certificate and it represents the information on the product in the ABS Records as of the date and time the certificate was printed. Type Approval requires Drawing Assessment, Prototype Testing and assessment of the manufacturer's quality assurance and quality control arrangements. Limited circumstances may allow only Prototype Testing to satisfy Type Approval. The approvals of Drawings and Products remain valid as long as the ABS Rule, to which they were assessed, remains valid. ABS cautions manufacturers to review and maintain compliance with all other specifications to which the product may have been assessed. Further, unless it is specifically indicated in the description of the product; Type Approval does not necessarily waive witnessed inspection or survey procedures (where otherwise required) for products to be used in a vessel, MODU or facility intended to be ABS classed or that is presently in class with ABS. Questions regarding the validity of ABS Rules or the need for supplemental testing or inspection of such products should, in all cases, be addressed to ABS.

ABS Quality Evaluations

Certificate Of Conformance

This is to certify that the Environment Management System of:

Danfoss Sea Recovery Corp./Horizon Reverse Osmosis

19610 South Rancho Way
Rancho Dominguez, CA 90220
U.S.A

has been assessed by ABS Quality Evaluations, Inc. and found to be in conformance with the requirements set forth by:

ISO 14001:2004

The Environment Management System is applicable to:

DESIGN AND MANUFACTURE OF REVERSE OSMOSIS DESALINATORS FOR THE MARINE INDUSTRY

Certificate No: 46063
Effective Date: 18 January 2012
Expiration Date: 17 January 2015
Issue Date: 18 January 2012

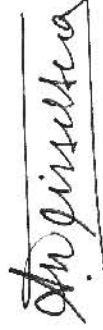

Alex Weisselberg, President



Validity of this certificate is based on the periodic audits of the management system defined by the above scope and is contingent upon prompt, written notification to ABS Quality Evaluations, Inc. of significant changes to the management system or components thereof.

ABS Quality Evaluations, Inc. 16855 Northchase Drive, Houston, TX 77060, U.S.A.

Validity of this certificate may be confirmed at www.abs-qe.com/cert_validation.

ABS Quality Evaluations

Certificate Of Conformance

This is to certify that the Quality Management System of:

Danfoss Sea Recovery Corp./Horizon Reverse Osmosis

19610 South Rancho Way
Rancho Dominguez, CA 90220
U.S.A

has been assessed by ABS Quality Evaluations, Inc. and found to be in conformance with the requirements set forth by:

ISO 9001:2008

The Quality Management System is applicable to:

DESIGN AND MANUFACTURE OF REVERSE OSMOSIS DESALINATORS

Certificate No: 45511
Effective Date: 28 December 2010
Expiration Date: 27 December 2013
Issue Date: 02 February 2011

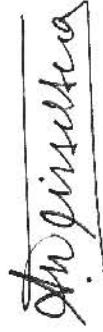

Alex Weisselberg, President



Validity of this certificate is based on the periodic audits of the management system defined by the above scope and is contingent upon prompt, written notification to ABS Quality Evaluations, Inc. of significant changes to the management system or components thereof.

ABS Quality Evaluations, Inc. 16855 Northchase Drive, Houston, TX 77060, U.S.A.

Validity of this certificate may be confirmed at www.abs-qe.com/cert_validation.



Horizon Reverse Osmosis

2630 E. El Presidio Street

Carson, CA 90810

sales@hrosystems.com

www.hrosystems.com